



DESCRIPTION

The 8483-6000 is a radiation type, parallel flow recuperator suitable for handling flue gases up to 2400 F.

INSTALLATION

The recuperator should be mounted at an elbow of the flue. This reduces the radiant energy intensity at the inlet of the recuperator. Mounting a recuperator directly on a furnace can "rob" heat from the furnace chamber and reduce the furnace heating effectiveness.

The flue should be sized for no larger than the ID of the radiation can (10 5/8").

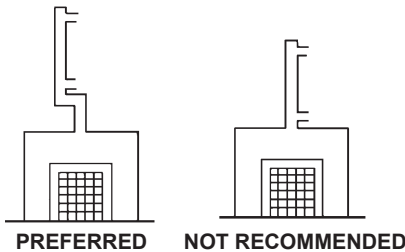

Flue gases may have a moderate amount of particulates but should have no elements corrosive to stainless steel (such as oxides of molybdenum and tungsten). For glass melting and similar installations, performances shown on the next page will only occur with a radiation can free of deposits. A build-up of a deposit layer on the radiation can will act as an insulator and will result in lower preheats.

Flexible connections should be installed in the inlet cold air and outlet hot air pipes and (if there is one) the exit flue gas duct. Connecting piping should be independently supported and should not rest on the recuperator. The recuperator should be insulated with at least 2" of a 6-8 lb/ft² blanket.

A type K contact thermocouple is included in the recuperator assembly for measurement of radiation tube temperature. The thermocouple should be connected to a protection system to prevent overheating the recuperator. Typical systems either bleed dilution air into the flue gas stream upstream of the recuperator, or bleed preheated air from the recuperator air outlet to maintain sufficient air flow rate through the recuperator. The thermocouple should be periodically checked to make sure good contact is being made with the radiation can. Consult your North American field engineer for assistance on an appropriate protection system for your recuperator and furnace. A small amount of air is bled from the air inlet to cool the top end seals.

Series 8483 Recuperators at maximum temperature and flow rate will require up to 0.08"wc flue gas pressure drop. For most types of furnaces and recuperator locations this should not present a problem of excessive furnace pressure. Consideration should be given to the resulting furnace pressure if the recuperator is mounted low in a side wall of a relatively tall furnace.

† Flue gas leakage, (out of door cracks for instance) may result in a reduction of the actual volume of flue gases passing through the recuperator. This should be considered when estimating air preheat temperatures.

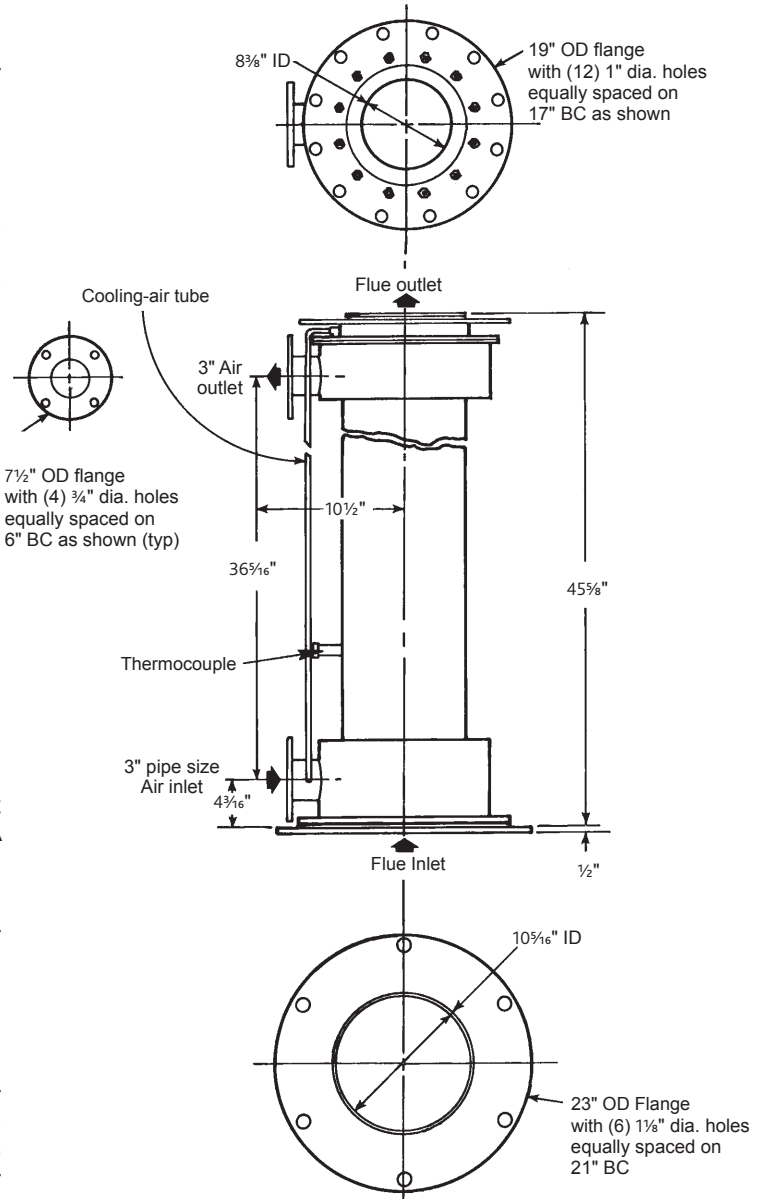

SELECTION PROCEDURE

Given: scfh preheated air
flue gas temperature

- 1. Enter selection chart (page 2) at scfh air, and locate intersection with flue gas temperature line.
- 2. Read available air preheat temperature and total pressure drop directly from curves.

Selection Example: scfh, 5250
flue gas temperature, 2200 F

- 1. Enter chart at 5250 scfh.
- 2. Locate intersection with 2200 F flue gas temperature on grid.
- 3. Read air preheat achieved (about 840 F)†.
- 4. Read total air side pressure drop (about 6.6"wc).

8483-6000 RECUPERATOR

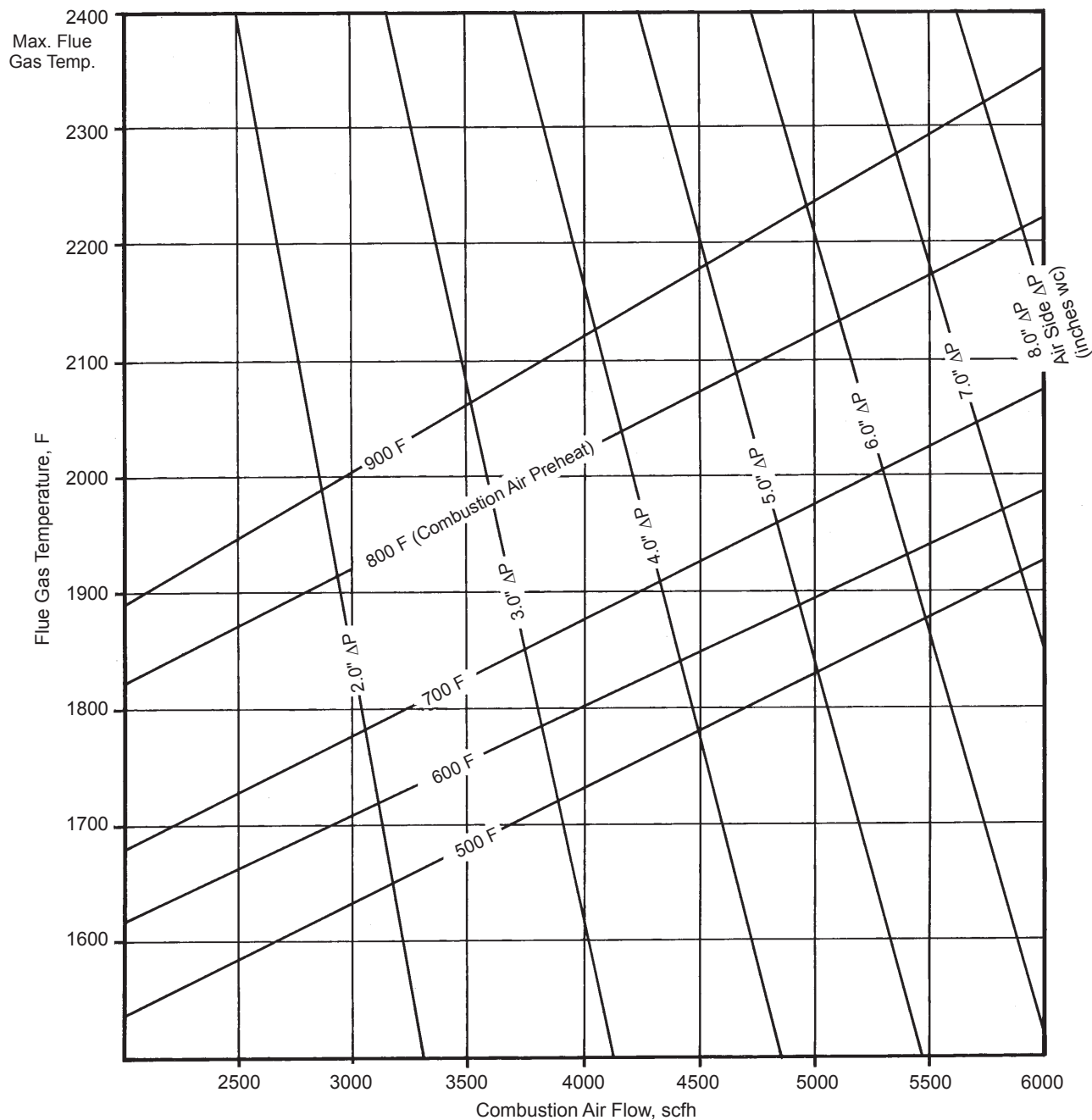

Preheats are based on typical furnace applications operating at 10% XSAir with all flue gas flowing through recuperator.

WARNING: Situations dangerous to personnel and property may exist with the operation and maintenance of any combustion equipment. The presence of fuels, oxidants, hot and cold combustion products, hot surfaces, electrical power in control and ignition circuits, etc., are inherent with any combustion application. Parts of this product may exceed 160F in operation and present a contact hazard. Fives North American Combustion, Inc. urges compliance

Fives North American Combustion, Inc. - 4455 East 71st Street - Cleveland, OH 44105 USA - Phone 216.271.6000
Fax 216.641.7852 - email: fna.sales@fivesgroup.com - www.fivesgroup.com/fivesna