

**DESCRIPTION**

The 8483-24000 is a radiation type, parallel flow recuperator suitable for handling flue gases up to 2400 F.

**INSTALLATION**

The recuperator should be mounted at an elbow of the flue. This reduces the radiant energy intensity at the inlet of the recuperator. Mounting a recuperator directly on a furnace can "rob" heat from the furnace chamber and reduce the furnace heating effectiveness. The flue should be sized for no larger than the radiation can (13").

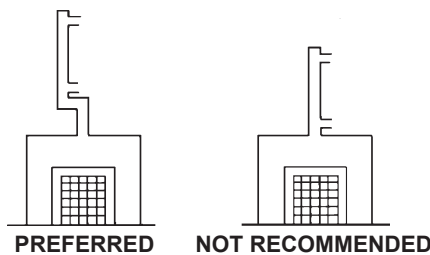

Flue gases may have a moderate amount of particulates but should have no elements corrosive to stainless steel (such as oxides of molybdenum and tungsten). For glass melting and similar applications, buildup of particulates on the radiation can causes a reduction in preheat from the indicated levels on page 2.

Flexible connections should be installed in the inlet cold air and outlet hot air pipes and (if there is one) the exit flue gas duct. Connecting piping should be independently supported and should not rest on the recuperator. The recuperator should be insulated with at least 2" of a 6-8 lb/ft<sup>3</sup> blanket.

A type K contact thermocouple is included in the recuperator assembly for measurement of radiation tube temperature. The thermocouple should be connected to a protection system to prevent overheating the recuperator. Typical systems either bleed dilution air into the flue gas stream upstream of the recuperator, or bleed preheated air from the recuperator air outlet to maintain sufficient air flow rate through the recuperator. The thermocouple should be checked periodically to ensure good contact is maintained with the radiation can. Consult your North American field engineer for assistance on an appropriate protection system for your recuperator and furnace.

At the bottom end of the unit a sand seal has been provided for prevention of flue gas leakage. Approximately 30 pounds of #40 industrial grade garnet is recommended and can be supplied by North American (R685-1200). Do not work sand up into the area between the sealing ring and the radiation can. Simply pour sand until level reaches top of sealing ring.

Series 8483 Recuperators, at maximum temperature and flow rate, will require up to 0.08"wc flue gas pressure drop. For most types of furnaces and recuperator locations this should not present a problem of excessive furnace pressure.

Special consideration should be given to the resulting furnace pressure in tall furnaces if recuperators are mounted low on side or end walls.

An optional motorized damper is available for furnace pressure control.

† Flue gas leakage, (out of door cracks for instance) may result in a reduction of the actual volume of flue gases passing through the recuperator. This should be considered when estimating air preheat temperatures.

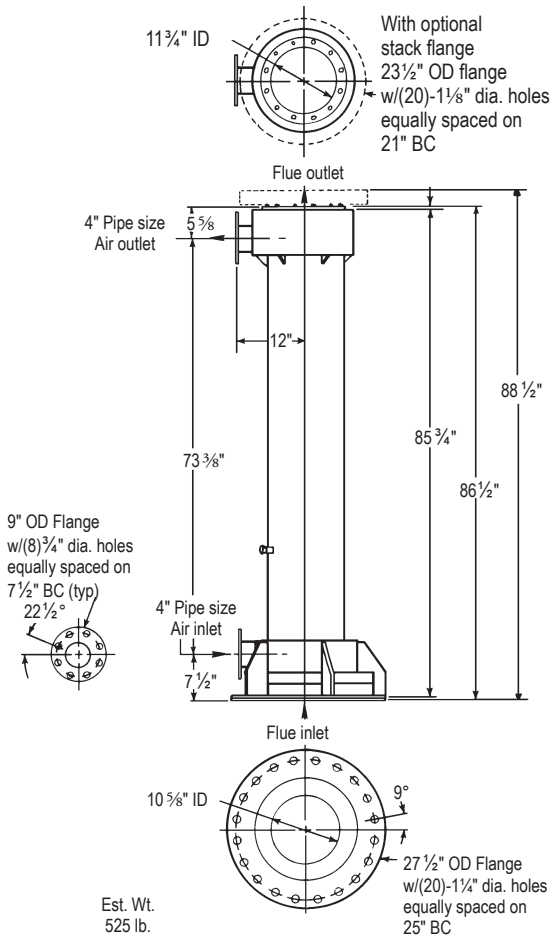

**SELECTION PROCEDURE**

Given: scfh preheated air  
 flue gas temperature

1. Enter selection chart (page 2) at scfh air, and locate inter-section with flue gas temperature line.
2. Read available air preheat temperature and total pressure drop directly from curves.

**Selection Example:** scfh, 20 000  
 flue gas temperature, 2000 F

1. Enter chart at 20 000 scfh.
2. Locate intersection with 2000 F flue gas temperature on grid.
3. Read air preheat achieved (about 730 F).†
4. Read total air side pressure drop (about 7.6"wc).

**8483-24000 RECUPERATOR**

Max. Flue Gas Temp.

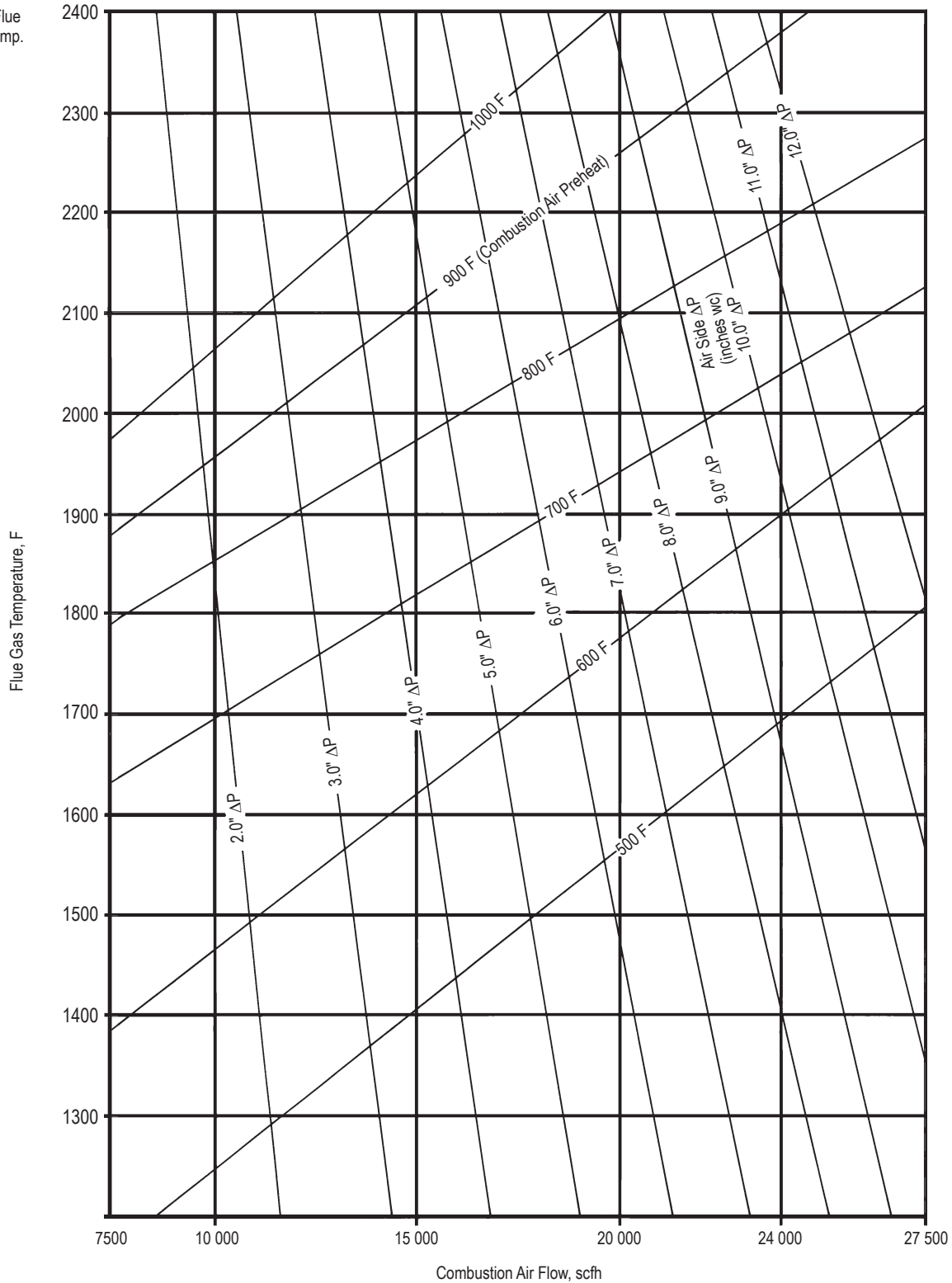

Preheats are based on typical operating conditions at 10% excess air and all flue gas flowing through recuperator.

**WARNING:** Situations dangerous to personnel and property may exist with the operation and maintenance of any combustion equipment. The presence of fuels, oxidants, hot and cold combustion products, hot surfaces, electrical power in control and ignition circuits, etc., are inherent with any combustion application. Parts of this product may exceed 160F in operation and present a contact hazard. Fives North American urges compliance with National Safety Standards and insurance Underwriters recommendations, and care in operation.

Fives North American Combustion, Inc., 4455 East 71st Street, Cleveland, OH 44105 USA, Phone 216.271.6000  
Fax 216.641.7852 email: [fna.sales@fivesgroup.com](mailto:fna.sales@fivesgroup.com) • [www.fivesgroup.com/fivesna](http://www.fivesgroup.com/fivesna)