

**DESCRIPTION**

The 8486-60000 is a radiation type, parallel flow recuperator suitable for handling flue gases up to 2400 F.

**INSTALLATION**

The recuperator should be mounted at an elbow of the flue. This reduces the radiant energy intensity at the inlet of the recuperator. Mounting a recuperator directly on a furnace can "rob" heat from the furnace chamber and reduce the furnace heating effectiveness.

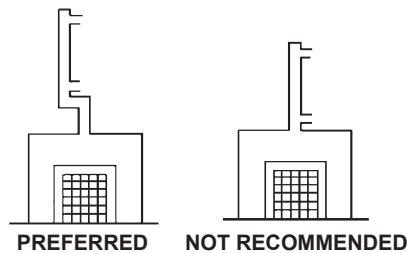

Flue gases may have a moderate amount of particulates but should have no elements corrosive to stainless steel (such as oxides of molybdenum and tungsten).

Flexible connections should be installed in the inlet cold air and outlet hot air pipe and (if there is one) the exit fluegas duct. Connecting piping should be independently supported and should not rest on the recuperator.

A thermocouple is included in the recuperator assembly for measurement of radiation tube temperature. The thermocouple should be connected to a protection system to prevent overheating the recuperator. Typical systems either bleed dilution air into the flue gas stream upstream of the recuperator, or bleed preheated air from the recuperator air outlet to maintain sufficient air flow rate through the recuperator. Consult your North American field engineer for assistance on an appropriate protection system for your recuperator and furnace.

The 8486 Recuperator at maximum temperature and flow rate will require up to 0.08"wc flue gas pressure drop. For most types of furnace and recuperator locations this should not present a problem of excessive furnace pressure.

**SELECTION PROCEDURE**

Given: scfh preheated air  
 flue gas temperature

1. Enter selection chart (page 2) at scfh air, and locate intersection with flue gas temperature line.
2. Read available air preheat temperature and total pressure drop directly from curves.

**Selection Example:** scfh, 58 000  
 flue gas temperature, 2200 F

1. Enter chart at 58 000 scfh.
2. Locate intersection with 2200 F flue gas temperature on grid.
3. Read air preheat achieved (about 740 F)†.
4. Read total air side pressure drop (about 13.8"wc).

Approximate weight 1500 lb

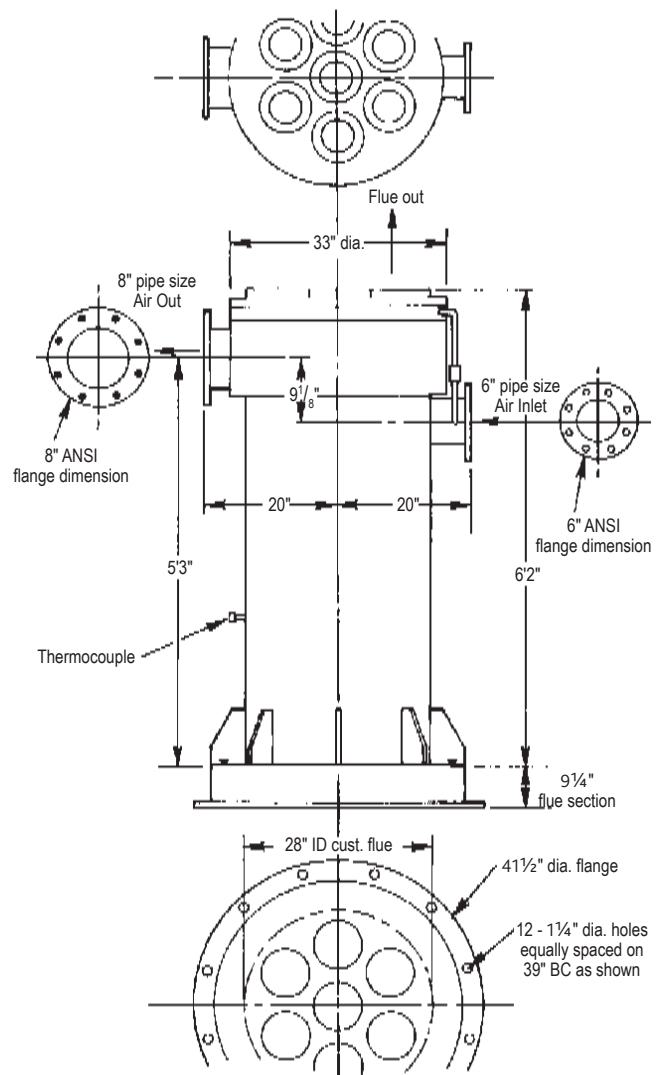

DIMENSIONS SHOWN ARE SUBJECT TO CHANGE. PLEASE OBTAIN CERTIFIED PRINTS FROM FIVES NORTH AMERICAN COMBUSTION, INC. IF SPACE LIMITATIONS OR OTHER CONSIDERATIONS MAKE EXACT DIMENSION(S) CRITICAL.

† Flue gas leakage, (out of door cracks for instance) may result in a reduction of the actual volume of flue gases passing through the recuperator. This should be considered when estimating air preheat temperatures.

**8486-60000 RECUPERATOR**

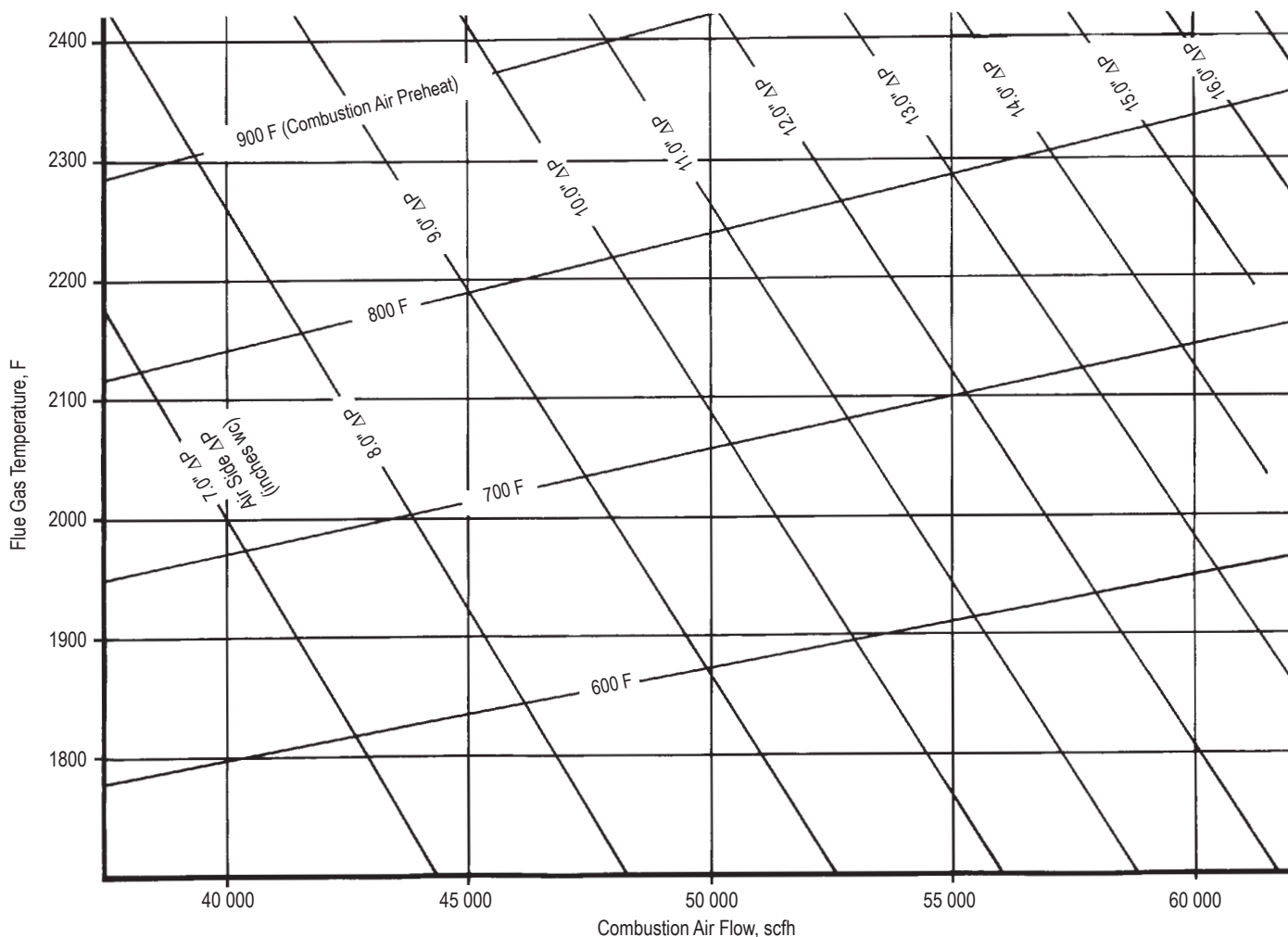

**Metric Conversions**

- 1 scfh = 0.028 26 sm<sup>3</sup>/h = 0.026 86 nm<sup>3</sup>/h
- 1"wc = 25.40 mm H<sub>2</sub>O
- C =  $\frac{5}{9}$  (F - 32)
- 1" = 25.40 mm
- 1 lb = 0.4536 kg

**WARNING:** Situations dangerous to personnel and property may exist with the operation and maintenance of any combustion equipment. The presence of fuels, oxidants, hot and cold combustion products, hot surfaces, electrical power in control and ignition circuits, etc., are inherent with any combustion application. Parts of this product may exceed 160F in operation and present a contact hazard. Fives North American Combustion, Inc. urges compliance with National Safety Standards and insurance Underwriters recommendations, and care in operation.