

8864 Direct Drive Pumps for light oil (30-100 SSU) include TEFC motors and integral relief valves that are factory set at 135 psi but can be field adjusted. Outlet pressure must not exceed 250 psi. Capacity increases with reduced downstream pressure due to less slippage of oil past the pump gears.

Select a pump with a rating 1.5 times maximum system firing rate.

Several systems can be used for oil pressure control. The preferred loop system uses an external relief valve to control oil pressure, sending excess oil back to the pump inlet or the tank. It facilitates purging air from the system. The internal relief valve opens only if discharge pressure rises above 135 psi due to malfunction of the external relief valve.

The simplest system (not recommended by North American) is dead end. It uses a pressure regulator between pump and burner. The integral relief valve controls pressure to the regulator, which reduces it to burner requirements. This system uses a minimum of piping, but purging can be difficult.

The pumps have mechanical seals and should be located so lift is as small as possible, not exceeding 20 feet including friction losses in pipe and fittings. 50 hertz oil pumps, pumps for larger capacities, or pumps for heavy oil are available on special order--consult North American.

The oil pump set price does not include the starter switch or heaters. Please see sheet 8564-3 for the starter switch and heaters selection chart, if these items are required. These parts must be listed separately on the order and will ship as loose items with the pump set. They are not mounted or wired to the pump set assembly.

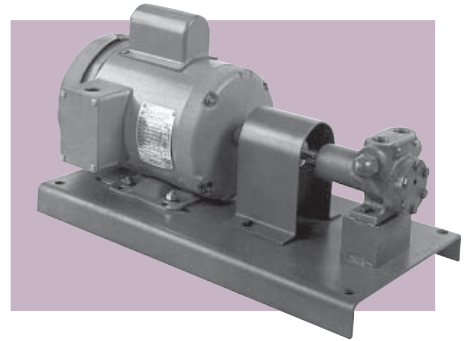

8564 PUMP SPECIFICATIONS

Pump designation	gph						Pipe size	Motor hp	Motor rpm	Integral Relief Valve setting, psi		wt, lb complete
	125 psi†		70 psi†		35 psi†					Start to Open	Full Open	
	38 SSU	100 SSU	38 SSU	100 SSU	38 SSU	100 SSU						
8564-1.5	81	108	96	114	108	117	1/2"	1/3	1800	135	160	53
8564-3.5	168	190	186	198	198	204	1/2"	1/2	1800	135	160	60

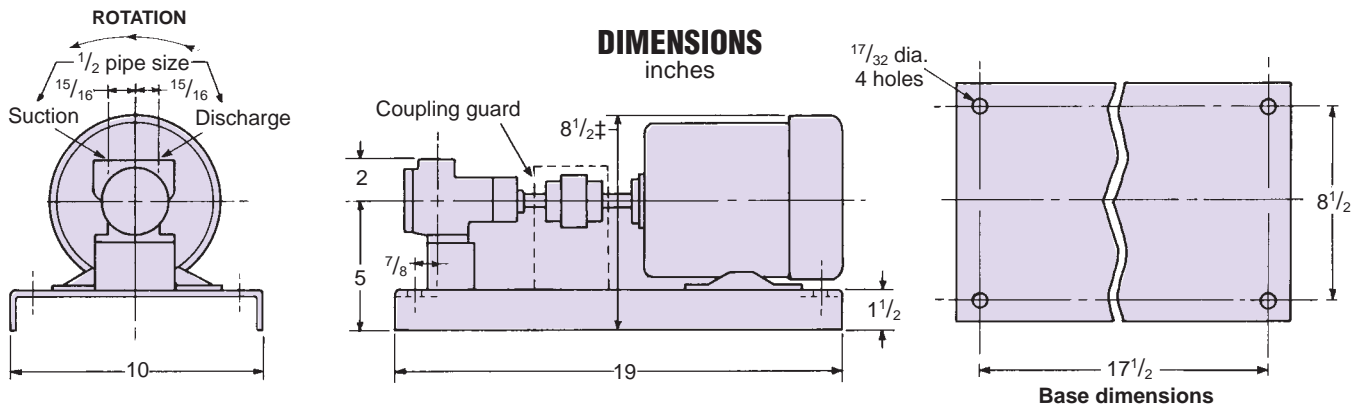

DIMENSIONS SHOWN ARE SUBJECT TO CHANGE. PLEASE OBTAIN CERTIFIED PRINTS FROM FIVVES NORTH AMERICAN COMBUSTION, INC. IF SPACE LIMITATIONS OR OTHER CONSIDERATIONS MAKE EXACT DIMENSION(S) CRITICAL.

To order, specify: 8564-1.5 (or 3.5) - (1 for single phase, 3 for three phase) Oil Pump.

† Set by system relief valve--not the integral pump relief valve.
‡ Add 2" for single phase motor because of capacitor on top (see photo).

8563- -A PUMP SET SPECIFICATIONS

8563- -A Pump Sets consist of an 8564 Pump with appropriate accessory equipment pre-piped for convenience.

Circled item numbers apply to drawing on back.

Pump Set	Oil Pump ^① with TEFC motor	Diaphragm Relief Valve ^③	Basket Type Strainer ^②	Horizontal Swing Check Oil Valve ^④	Pressure Gauge [®] and 1/4" Needle Valve (1836-03) ^⑤
8563-1.5	8564-1.5	7177-01-75 (or 150) (1/2")	8553-0 (3/4")	R920-1413 (3/4")	8735-S (0-160 psi)
8563-3.5	8564-3.5	7177-01-75 (or 150) (1/2")	8553-1 (1")	R920-1423 (1")	8735-S (0-160 psi)

⑤ Bracket 11-14494-1

⑥ Bracket Strap 4-11852-1

⑦ Pump Information Decal

DIMENSIONS

inches

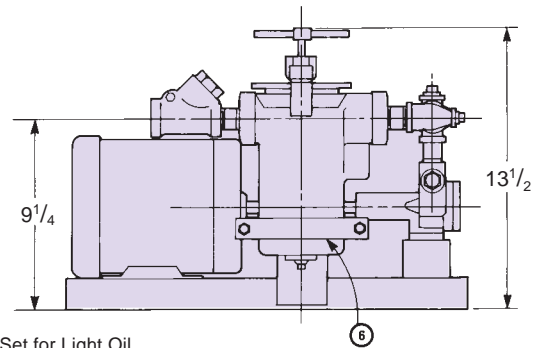
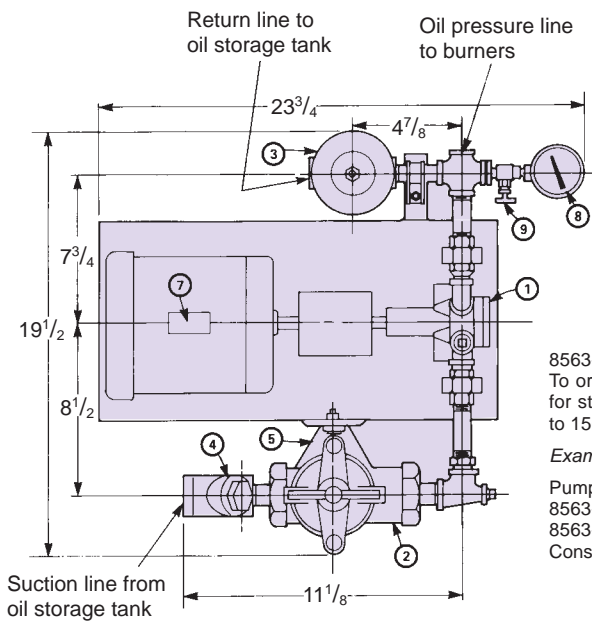

8563- -A Packaged Pump Set for Light Oil
To order, specify: 8563-1.5 (or 3.5) - (1 for single phase or 3 for three phase) / A modifier (75 for st'd spring [25 to 75 psig range] in relief valve, 150 for special spring at additional cost [70 to 150 psig]).

Example: 8563-3.5-3/A75 Oil Pump Set assembled (st'd spring in relief valve)

Pump will be supplied with TEFC motor. Electrical power to be as follows:

8563-1.5 (or 3.5)-1 Electric: 115/230/1/60

8563-1.5 (or 3.5)-3 Electric: 230/460/3/60

Consult North American Mfg. Co. for special power requirements.

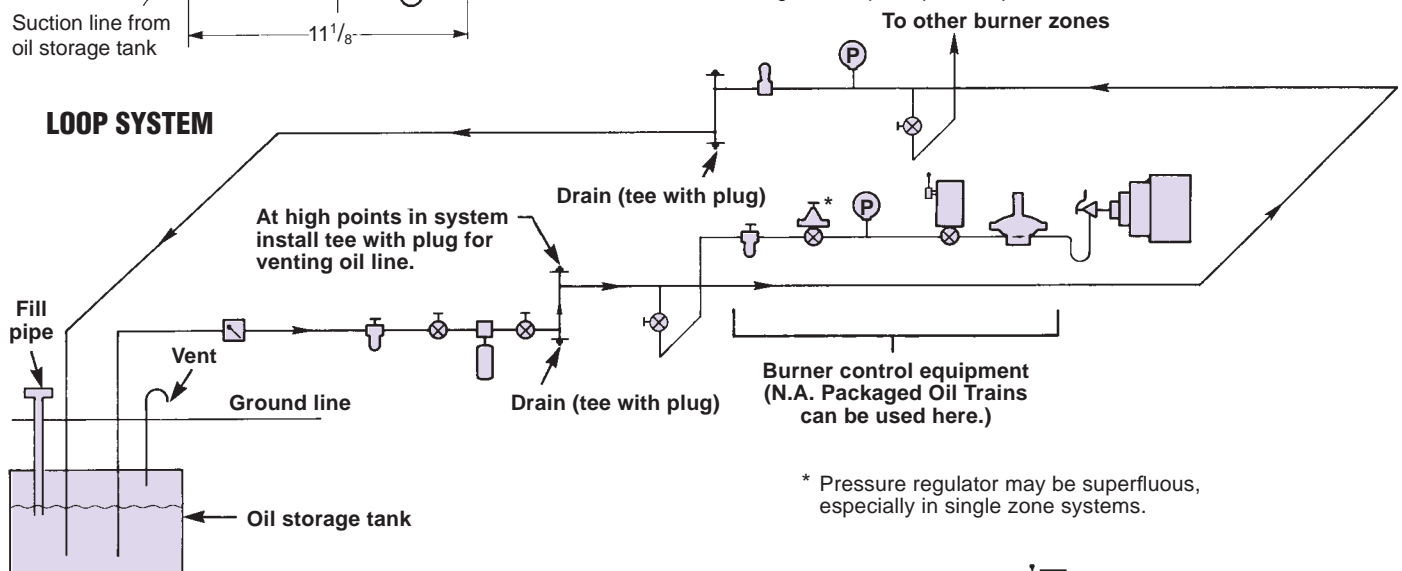

* Pressure regulator may be superfluous, especially in single zone systems.

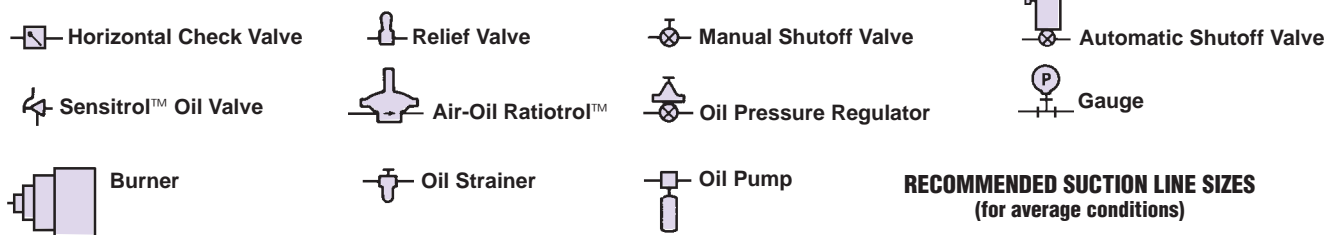

RECOMMENDED SUCTION LINE SIZES (for average conditions)

Pump set	Pipe size
8563-1.5	3/4"
8563-3.5	1"

Refer to local codes for recommended installation information.

Use black iron pipe for oil lines.

Use an oil resistant pipe joint compound.

Suction line intake should be at least 2" off bottom of tank to allow for water and sediment accumulation. In large tanks, clearance up to 6" is recommended.

Suction line must be as short as possible and absolutely leak tight to prevent pulling air into oil system. Suction line should pitch toward tank.

All "take offs" to oil burners should be made from the bottom of main oil line piping to prevent air bubbles from entering burners.

Burner should be above oil manifold to avoid oil siphoning through burner.

WARNING: Situations dangerous to personnel and property may exist with the operation and maintenance of any combustion equipment. The presence of fuels, oxidants, hot and cold combustion products, hot surfaces, electrical power in control and ignition circuits, etc., are inherent with any combustion application. Parts of this product may exceed 160F in operation and present a contact hazard. Fives North American urges compliance with National Safety Standards and insurance Underwriters recommendations, and care in operation.

Fives North American Combustion, Inc., 4455 East 71st Street, Cleveland, OH 44105 USA, Phone 216.271.6000
Fax 216.641.7852 email: fna.sales@fivesgroup.com • www.fivesgroup.com/fivesna