

FOR NOZZLE-MIX BURNERS WITH LOW AVAILABLE GAS PRESSURE

If plant gas pressure is less than combustion air pressure, 8654 Bleeders allow a constant air/gas ratio to be held by cross-connected ratio regulators feeding nozzle-mix burners.

APPLICATION

To maintain gas and air flows proportional to each other from high fire to low, air impulse pressure to the regulator at high fire must be reduced below maximum available gas pressure (inlet pressure to regulator less pressure drop across regulator at high fire).

An 8654 Bleeder accomplishes this reduction in impulse pressure.

Example: A burner is sized for **14 osi** air pressure at the burner. Maximum inlet gas pressure into a North American 7218 or 7216 Regulator is 12 osi.

The regulator will take about 2 osi drop to pass appropriate cfm gas at high fire, leaving **10 osi** at regulator outlet.

Therefore, at least **4 osi** air impulse must be bled to reduce it below 10 osi (good practice would bleed 5-6 osi to provide a little margin).

Such bleed arrangement maintains a constant relationship between air pressure and gas pressure going to the burner from high fire to low.

Ratio changes due to combustion chamber pressure fluctuations are neutralized by connecting a third line from bleeder to combustion chamber (see sketch). This arrangement applies pressure variations to both sides of regulator diaphragm.

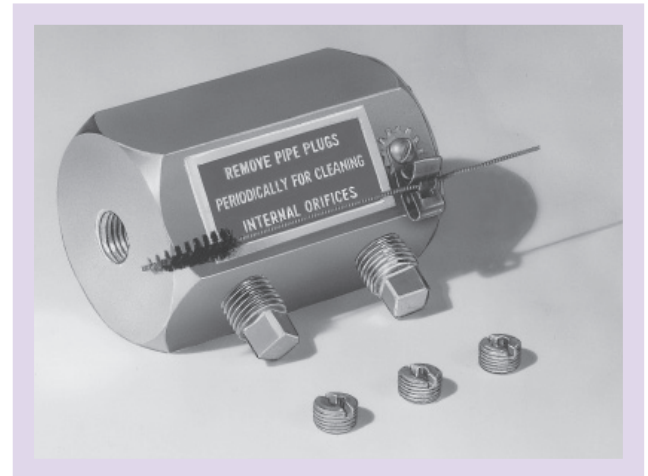

INSTALLATION

Make impulse connection to air manifold by welding a half coupling on top or side of pipe; then drill a 1/2" hole through pipe. Remove burrs from the inside.

Locate connection at least 5 pipe diameters downstream and 3 diameters upstream of any valve or fitting.

Bleeders should be installed as close to the air line as possible to speed response by minimizing pressure drop through that part of the impulse line in which air flows. On very short impulse runs with low bleed rates 1/4" pipe may be okay--never 1/4" tubing. 3/8" pipe or tubing is preferred, with a reducer at the bleeder.

CLEANING

In installations with excessive dirt in the air, frequent cleaning is required. This is accomplished by brushing out all orifices. Clean-out plugs in the bleeder and a convenient brush are provided for orifice cleaning.

An alternate to the 8654 Bleeder with brush is the 8655 Bleeder and Filter assembly: An 8654 Bleeder with 8647-01 Filter.

Filter elements must be replaced when they accumulate enough dirt to cause an additional decrease in impulse pressure and accompanying lean burner operation. If the filter element is allowed to plug with dirt, its pressure drop will increase, changing air/fuel ratio. Spare filter elements (2-4920-1) are recommended.

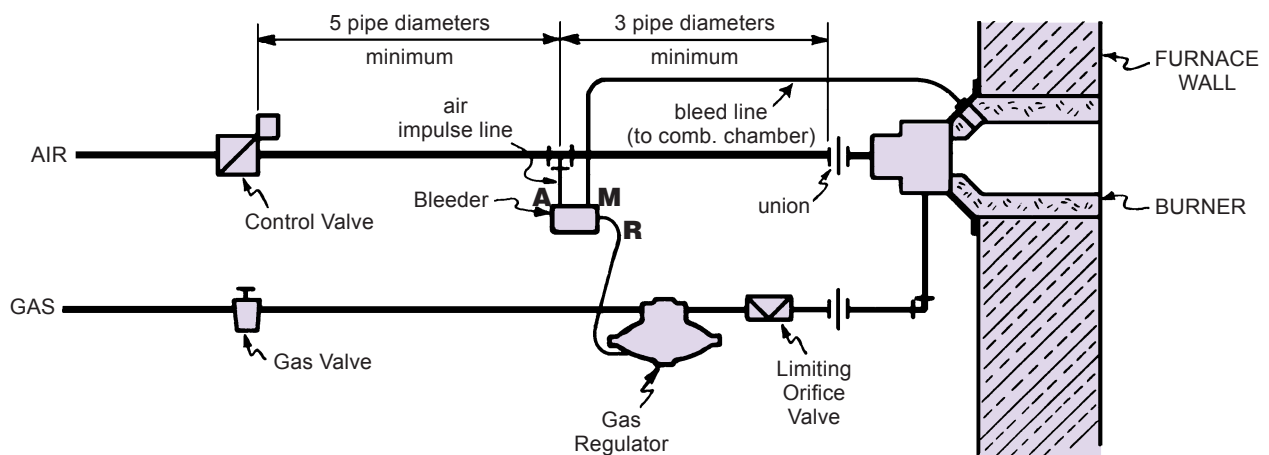

8654 and 8655 Bleeders have aluminum bodies to minimize rust problems. They are furnished with four interchangeable orifice plugs. One is undrilled, the other three drilled for various bleeds indicated in Table A as "Standard."

To determine most appropriate orifice, divide maximum gas pressure at ratio **regulator outlet** by air pressure; then use the orifice giving the next lower % impulse pressure.

The bleeder and the filter are intended for use on low pressure combustion air only and have a maximum operating pressure of 2 psi.

In the example on the front side: 10 psi gas ÷ 14 psi air = 71%. Use the 57% (#32 drill) orifice. Or bore it out with a #38 drill for 70% impulse.



To determine optimum orifice through trial and error:
Light burner, bring it to high fire, and adjust limiting orifice valve for desired air/gas ratio.

Insert smallest orifice (#32 drill) into "M" opening in bleeder. If flame indicates drop in gas flow, use this orifice; or make a smaller one by drilling blank plug. (It is desirable to have impulse pressure as high as possible as finally set via the bleed at high fire; and the smaller the orifice, the higher the impulse pressure.)

If #32 orifice does not cause a drop in gas flow, try successively larger orifices until an effect is observed.

Readjust limiting orifice valve for desired air/gas ratio. Burner will maintain that ratio at all firing rates.

TABLE A

	Impulse as a % of air pressure	Orifice drill size	part number
Standard	10	# 8 	OA2-0401-1
	30	25 	OA2-0401-2
	57	32 	OA2-0401-3
Special	15	15	
	20	19	
	40	29	
	70	38	
	82	44	

User can make one of these orifices by drilling blank plug included with each bleeder or by enlarging one of the 3 Standard orifices. Drill plug from end opposite slot. Remove burrs and insert plug so slotted surface is about 1/2" below surface.

DIMENSIONS

inches

8654 Bleeder
wt. 1 lb

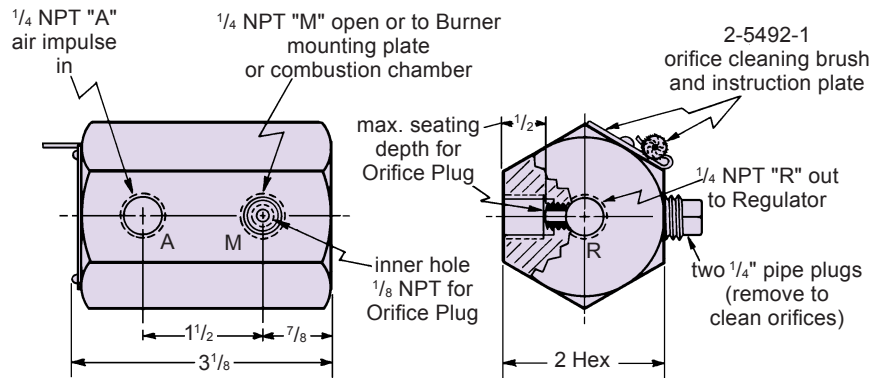

8655 Bleeder and Filter Assembly
wt. 2 lb

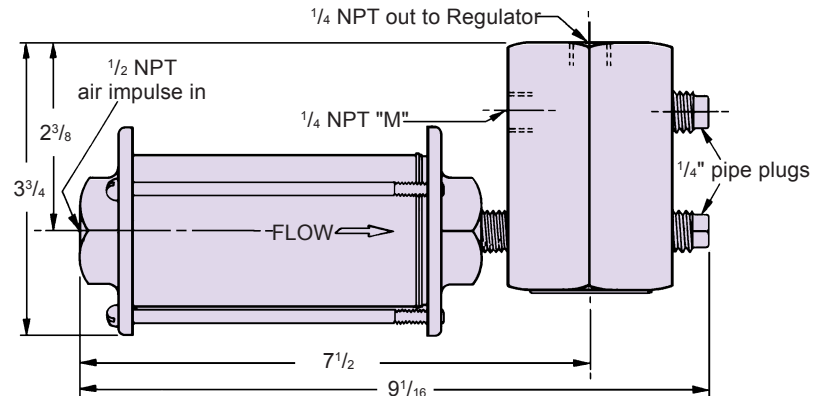

To order, specify: 8654 Bleeder, or 8655 Bleeder-Filter.

DIMENSIONS SHOWN ARE SUBJECT TO CHANGE. PLEASE OBTAIN CERTIFIED PRINTS FROM FIVES NORTH AMERICAN COMBUSTION, INC. IF SPACE LIMITATIONS OR OTHER CONSIDERATIONS MAKE EXACT DIMENSION(S) CRITICAL.

WARNING: Situations dangerous to personnel and property may exist with the operation and maintenance of any combustion equipment. The presence of fuels, oxidants, hot and cold combustion products, hot surfaces, electrical power in control and ignition circuits, etc., are inherent with any combustion application. Parts of this product may exceed 160F in operation and present a contact hazard. Fives North American urges compliance with National Safety Standards and insurance Underwriters recommendations, and care in operation.

Fives North American Combustion, Inc., 4455 East 71st Street, Cleveland, OH 44105 USA, Phone 216.271.6000
Fax 216.641.7852 email: fna.sales@fivesgroup.com • www.fivesgroup.com/fivesna