

An 8699 Balancing Orifice is used at each burner on a gas manifold feeding multiple burners to assure equal flow to every burner.

The Balancing Orifice is sized to take a pressure drop significantly larger than any other drop in the manifold or individual piping to each burner. Therefore, it compensates for variations in pipe lengths and configurations that otherwise would cause uneven flows to the burners.

8699 Orifices are used in place of individual limiting orifice valves. They cannot be used for accurate metering--8697 Metering Orifices perform that function.

SELECTION

Pick orifice size for the largest practical pressure drop (see Table 1 on back).

General guideline: Select pressure drop equal to about half the **maximum** outlet pressure from the ratio regulator.

Note in Table 1 there are two standard orifice sizes for each pipe size. □ With 8 osi pressure drop, the larger orifice results in about 40 fps gas velocity in the pipe, the smaller orifice about 30 fps.

Example: Select Balancing Orifices for a bank of burners, each requiring 3000 cfm natural gas at high fire, with 12 osi pressure available in manifold. Drop across Balancing Orifice should be at least 6 osi (half of 12). From Table 1, choose the 8699-4-875: At 6 osi drop, its rated flow is 2985 cfm, which makes it suitable for "balancing" the 3000 cfm requirement.

Note: Pipe size of selected Balancing Orifice may not match burner gas pipe size (8699 usually will be one or more sizes smaller)--use appropriate reducing fitting at burner.

Balancing Orifices are not used with North American's Tempest® and other burners that, by design, require relatively high gas pressures during normal operation.

Table 1 lists flows at pressure drops up to 16 osi. If Balancing Orifice is to be used in a high pressure gas line with significantly higher drop, consult North American or the COMBUSTION HANDBOOK for appropriate orifice sizing.

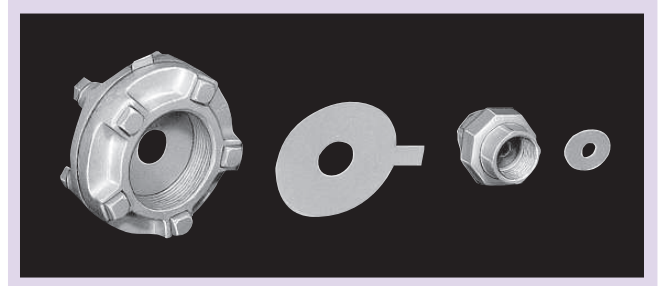

Figure 1. Balancing Orifices and holders.

INSTALLATION

Gas flow is controlled into the manifold by:

1. a single limiting orifice valve downstream of a cross-connected ratio regulator, or
2. a manual or motorized adjustable port or other type of gas control valve, or
3. a cross-connected regulator with a controlled impulse, usually via a manual or motorized bleed arrangement.

Figure 2 shows system #1 above: The limiting orifice valve is set for desired air/fuel ratio. All burners get the same cfm of gas because pressure drops through downstream pipe, fittings, cocks, etc. are insignificant relative to the drop across each individual Balancing Orifice.

For best results, install the 8699 unit in a straight run with at least 5 pipe diameters upstream, 2 diameters downstream of any valve or fitting.

CONSTRUCTION

In 1/2" through 2" pipe sizes, Balancing Orifices are threaded unions. 2 1/2", 3" and 4" pipe sizes are flanged unions.

Threaded 8699 units are specially machined malleable iron unions with jig-drilled stainless steel orifice plate and rubber gasket. An 8699 cast iron flange union has a bored, tabbed stainless orifice plate and two gaskets and hardware.

Accuracy is 5% in all standard Balancing Orifices. Special drillings are available at extra cost, but accuracy cannot be guaranteed when quantity required is 10 or less.

RATINGS

max. pressure: 50 psi
max. temperature:
250 F standard,
750 F with special construction

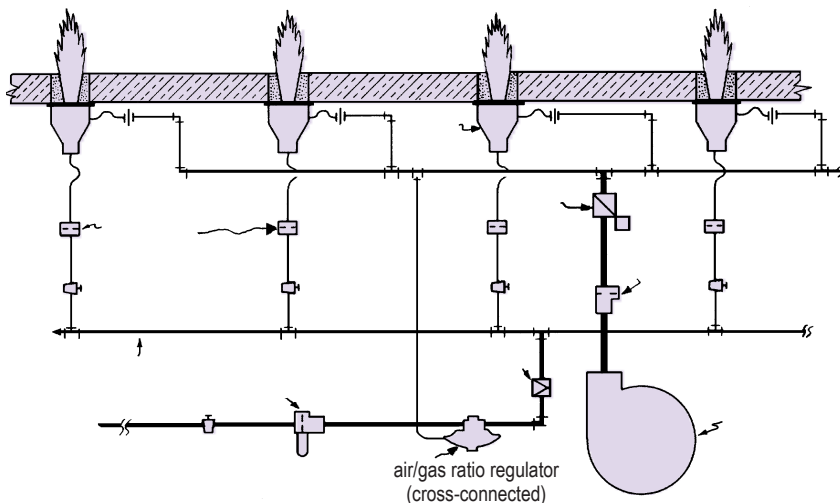
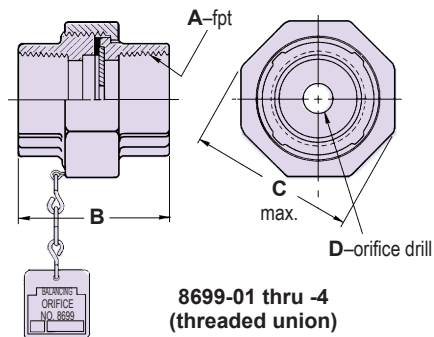
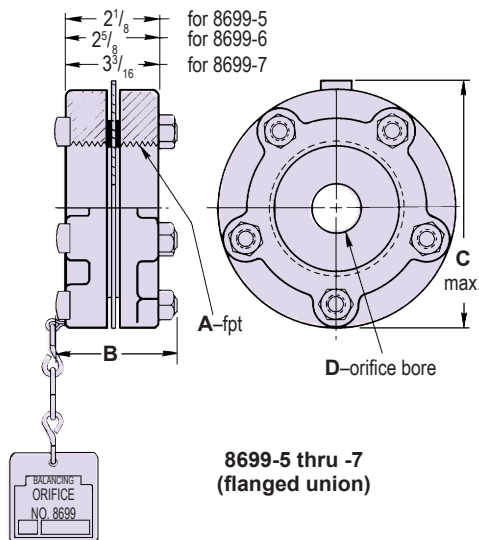

Figure 2. A properly sized Balancing Orifice in each burner's gas line assures an equal flow to every burner off the manifold, despite uneven pipe lengths and/or inconsistent welding or pipe-fitting practice. (Note: Schematic does not show all items required in air and gas pipes.)

□ The 8699-01 (1/2") Balancing Orifice has a third standard drilling: 0.073", which is used in the cross connection line of a bleed-impulse control system; it is too small for use as a balancing orifice.



**8699-01 thru -4
(threaded union)**



**8699-5 thru -7
(flanged union)**

DIMENSIONS SHOWN ARE SUBJECT TO CHANGE. PLEASE OBTAIN CERTIFIED PRINTS FROM FIVES NORTH AMERICAN COMBUSTION, INC. IF SPACE LIMITATIONS OR OTHER CONSIDERATIONS MAKE EXACT DIMENSION(S) CRITICAL.

TABLE 1: natural gas flow rates, cfh
pressure drop across orifice

| | dimensions in inches | | | | pressure drop across orifice | | | | wt, lb |
|------------------|----------------------|--------|--------|-------|------------------------------|--------|--------|---------|--------|
| | A | B | C | D | 6 osi | 8 osi | 12 osi | 16 osi† | |
| 8699-01-0 | 1/2 | 3/4 | 3/4 | * | | | | | |
| -01-073 | 1/2 | 3/4 | 3/4 | 0.073 | □ | □ | □ | □ | |
| -01-213 | 1/2 | 3/4 | 3/4 | 0.213 | 179 | 207 | 254 | 293 | 1/2 |
| -01-257 | 1/2 | 3/4 | 3/4 | 0.257 | 256 | 296 | 361 | 418 | |
| 8699-0-0 | 3/4 | 2 3/16 | 2 3/16 | * | | | | | |
| -0-295 | 3/4 | 2 3/16 | 2 3/16 | 0.295 | 347 | 400 | 489 | 564 | 3/4 |
| -0-343 | 3/4 | 2 3/16 | 2 3/16 | 0.343 | 475 | 548 | 670 | 776 | |
| 8699-1-0 | 1 | 2 3/16 | 2 7/16 | * | | | | | |
| -1-397 | 1 | 2 3/16 | 2 7/16 | 0.397 | 615 | 710 | 870 | 1 001 | 1 |
| -1-453 | 1 | 2 3/16 | 2 7/16 | 0.453 | 830 | 960 | 1 168 | 1 351 | |
| 8699-2-0 | 1 1/4 | 2 1/2 | 3 | * | | | | | |
| -2-500 | 1 1/4 | 2 1/2 | 3 | 0.500 | 961 | 1 110 | 1 357 | 1 570 | 1 1/2 |
| -2-562 | 1 1/4 | 2 1/2 | 3 | 0.562 | 1 230 | 1 420 | 1 734 | 2 010 | |
| 8699-3-0 | 1 1/2 | 2 3/4 | 3 3/8 | * | | | | | |
| -3-625 | 1 1/2 | 2 3/4 | 3 3/8 | 0.625 | 1 553 | 1 793 | 2 290 | 2 537 | 2 1/4 |
| -3-687 | 1 1/2 | 2 3/4 | 2 3/8 | 0.687 | 1 862 | 2 155 | 2 639 | 3 042 | |
| 8699-4-0 | 2 | 3 1/8 | 4 | * | | | | | |
| -4-781 | 2 | 3 1/8 | 4 | 0.781 | 2 310 | 2 665 | 3 264 | 3 770 | 3 1/4 |
| -4-875 | 2 | 3 1/8 | 4 | 0.875 | 2 985 | 3 445 | 4 220 | 4 870 | |
| 8699-5-0 | 2 1/2 | 3 3/16 | 6 3/8 | * | | | | | |
| -5-968 | 2 1/2 | 3 3/16 | 6 3/8 | 0.968 | 3 575 | 4 130 | 5 050 | 5 840 | 4 |
| -5-1125 | 2 1/2 | 3 3/16 | 6 3/8 | 1.125 | 5 149 | 5 950 | 7 270 | 8 400 | |
| 8699-6-0 | 3 | 3 1/2 | 7 1/16 | * | | | | | |
| -6-1234 | 3 | 3 1/2 | 7 1/16 | 1.234 | 5 825 | 6 730 | 8 220 | 9 525 | 11 |
| -6-1359 | 3 | 3 1/2 | 7 1/16 | 1.359 | 7 275 | 8 400 | 10 030 | 11 880 | |
| 8699-7-0 | 4 | 4 | 8 1/8 | * | | | | | |
| -7-1547 | 4 | 4 | 8 1/8 | 1.547 | 8 941 | 10 330 | 12 620 | 14 600 | 19 3/4 |
| -7-1688 | 4 | 4 | 8 1/8 | 1.688 | 11 020 | 12 730 | 15 560 | 18 000 | |

flanged unions

Flow factors for other gases.

| | | | | | | |
|-------------|------|-----|------|------|------|------|
| gas gravity | 0.4 | 0.6 | 0.8 | 1.0 | 1.5 | 2.0 |
| multiplier | 1.22 | 1.0 | 0.87 | 0.77 | 0.63 | 0.55 |

- * Blank plate-hole to be machined by others.
- See note on front.
- † For higher pressure drops, see information under "Selection" on front.

WARNING: Situations dangerous to personnel and property may exist with the operation and maintenance of any combustion equipment. The presence of fuels, oxidants, hot and cold combustion products, hot surfaces, electrical power in control and ignition circuits, etc., are inherent with any combustion application. Parts of this product may exceed 160F in operation and present a contact hazard. Fives North American Combustion, Inc. urges compliance with National Safety Standards and insurance Underwriters recommendations, and care in operation.