

- Combustion control in a single unit
- Integral manual/auto functions
- Process flexibility through logic I/O
- Precise ratio control with compensated air flow
- 2-line 20-character display in % or engineering units
- EIA-485 communications port
- Easy-to-use, plain English configuration menu
- Simple trouble-shooting via concise diagnostic messages



The North American 8196 **MARC III** Combustion Controller provides process temperature and ratio control of industrial combustion applications. Logic commands sent from or received by the unit provide flexibility to the process. Alarm actions trigger the display of abnormal conditions, and they cause the unit to default to a safe operating mode no matter what the state of the process: purge, light off, or full fire.

Manual/automatic functions are integral to the **MARC III** keyboard.

MARC III CONTROL FUNCTIONS

For industrial processes, a precise mix of fuel and air for combustion produces key benefits such as, maximum efficiency, low emissions, safety, and low operating costs. The 8196 controls those variables in industrial furnaces, kilns, dryers, boilers, etc. It can react to status inputs from and send signals to the process to assure safe combustion conditions.

The **MARC III** is flexible. It operates in various control modes. Setpoints for temperature and ratio can be set locally or configured to receive a remote setpoint via 4-20 mA input. External logic can select one or both fuel flows and/or one or both air flows, enabling the user to manipulate them in a variety of ways.

MENU STRUCTURE

The **MARC™ III** menu system uses concise, straightforward prompts. Entry of parameters is by means of the unit's keypad. No other device, such as a hand held programmer, is necessary.

The menu provides the operator a great deal of flexibility in setting up control of the process. It features a scrolling display that follows a logical step by step sequence for the attributes of each input and the numerous options available in the unit. Default values make setup easy. All menu steps are in plain English...no cryptic codes that complicate and confuse the user.

ANALOG INPUTS AND OUTPUTS

Process temperature via type J, K, R, or S thermocouple is the primary controlled variable. Two fuel flow and two air flow inputs may be treated as linear or differential pressure with the square root extracted internally. One air flow may be compensated for combustion air temperature by means of a second thermocouple input. Each fuel and air signal can be switched into use independently by external logic and the setup menu.

Output signals to all control actuators are 4-20 mA.

LOGIC INPUTS, ALARM and LOGIC OUTPUTS

Logic inputs offer the choice of hold, purge, low fire, or excess air.

Maintenance and trouble shooting are simplified by clear alarm messages. Detailed information allows the user to pinpoint specific problem areas such as transmitter failure or internal system fault. Additionally, event or control outputs respond to logical states defined during configuration, telling the rest of the control system of process conditions detected by the **MARC III**. All alarm conditions trip the alarm relay to signal other parts of the control system of the failure. Also, the design of the 8196 causes it to respond in such a manner as to minimize the effect of the failure.

Event or logic control outputs close contacts whenever operator defined conditions are met within the process. One output serves each variable: process temperature, ratio, air flow, and fuel flow.

COMMUNICATIONS

The **MARC III** provides an EIA-485 port to communicate with other parts of the process control system. All process variable inputs and status conditions may be passed to the host computer. All control parameters--gain, reset, rate, and events--can be written into the 8196 should remote setup be selected. In order to preserve integrity and safety, certain parameters cannot be changed via the communication port including control of outputs, and calibration of the instrument input channels. Finally, remote access is denied when local configuration work is in progress. Once on line, the 8196 receives commands and delivers process information with minimal overhead and prompt response.

SPECIFICATIONS

Operating temperature: 0 to 130 F (-17 to 55 C)

Power source: 120 V ac (102-132 V ac) 0.25 amp 50-60 Hz

Dimensions:

Behind panel: $5\frac{1}{4}$ " \times $5\frac{1}{4}$ " \times 9" (133 \times 133 \times 229 mm)

Front panel: $6\frac{7}{16}$ " \times $6\frac{7}{16}$ " \times 1" (164 \times 164 \times 25 mm)

Panel cutout: $5\frac{7}{16}$ " \times $5\frac{7}{16}$ " (138 \times 138 mm)

ANALOG INPUTS

Process control and air temp compensation: Two galvanically isolated direct thermocouple inputs. Will accept type J, K, R, and S thermocouples. Couples are cold junction compensated. Accuracy: 0.2% of range \pm one digit typical and temperature drift.

Fuel inputs: Two 4-20 mA fuel inputs may be from orifice pressure transmitter or mass flow transmitters. Built-in software available to convert the inputs representations from pressure to flow.

Air inputs: Two 4-20 mA air inputs may be from orifice pressure transmitter or mass flow transmitters. Built-in software available to convert the inputs representations from pressure to flow.

Remote setpoint: One remote setpoint input is available. Selectable for control of temperature or air/fuel ratio.

Selection inputs: Customer supplied dry contacts switch the air, fuel, hold/stop, remote setpoint, purge, low fire, and excess air, powered by 12 V dc from 8196.

ANALOG OUTPUTS

Fuel and air motor drives: One fuel drive and one air drive, 4-20 mA each, 500 ohm maximum load impedance.

DIGITAL INPUTS

Eight circuits accepting dry contacts powered from 8196 for fuel and air selection, and for operating mode changes.

ALARMS

System and Warning alarms: One electro-mechanical, form C relay contact; 120 V ac, 1 A max.

LOGIC OUTPUTS

Event outputs: Four electro-mechanical relay, form A (NO) low voltage contacts. Outputs are configurable and can be menu selected for ratio, temperature, fuel flow, or air flow; contact rating 30 V dc max., 250 mA max.

FRONT PANEL

Keyboard: Tactile feedback.

Indicator lights: Fault, Alarm, Purge, Hold, Low Fire, Excess Air, and Remote Setpoint.

Display: 2 \times 20-character vacuum fluorescent.

WIRING DIAGRAM

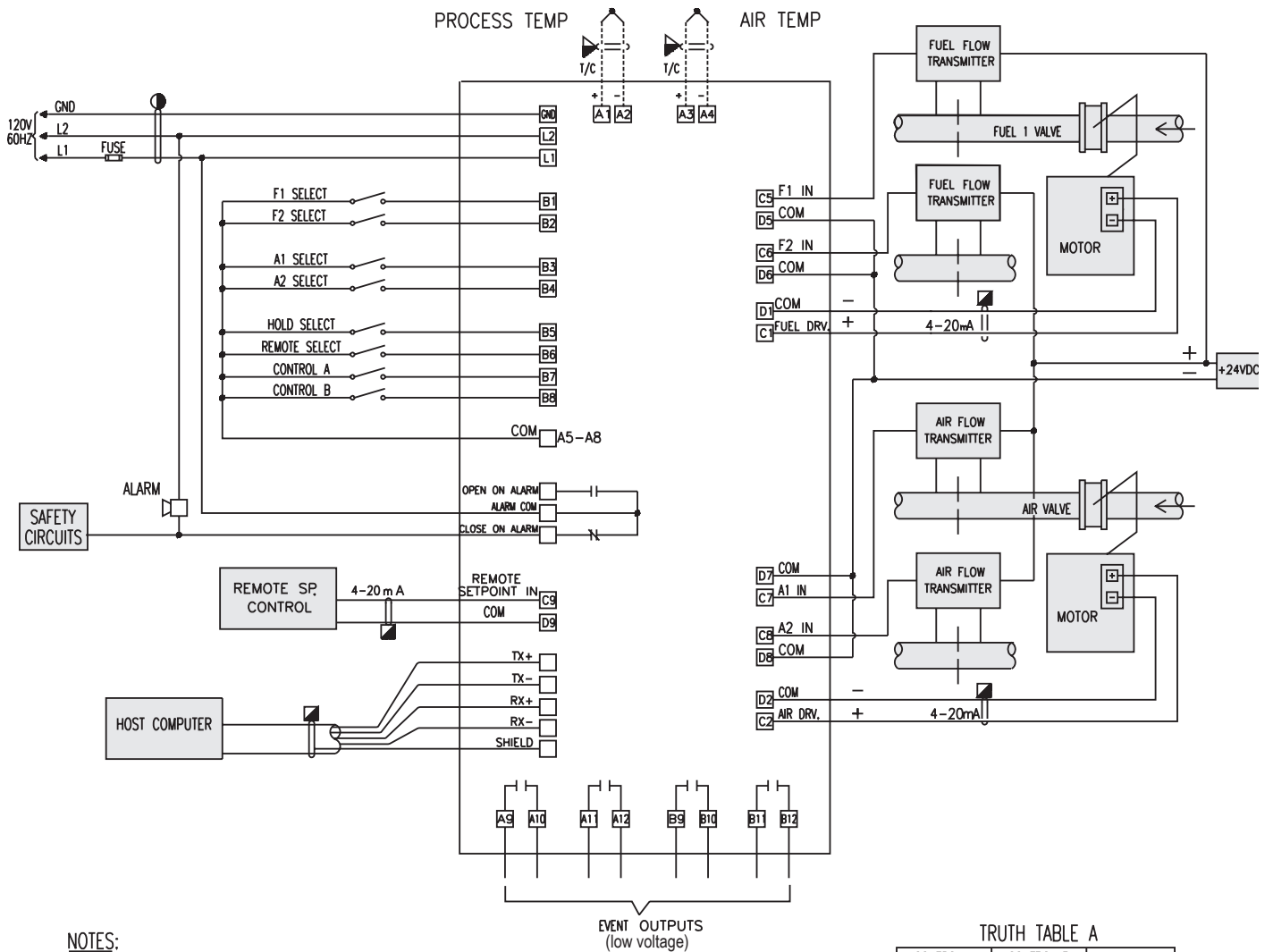

NOTES:

- RUN IN SEPARATE CONDUIT
- ▲ RUN T/C LEADS DIRECT IN SEPARATE CONDUIT
- RUN IN SHIELDED CABLE

TRUTH TABLE A

CONTROL A	CONTROL B	STATE
OFF	OFF	Normal
ON	OFF	Low Fire
OFF	ON	Purge
ON	ON	Excess Air

Fives North American Combustion, Inc.
 4455 EAST 71st STREET, CLEVELAND, OH 44105 USA
 216.271.6000 FAX: 216.641.7852

email: fna.sales@fivesgroup.com • www.fivesgroup.com/fivesna

fives north american 