



3070 High Pressure Inspirators use the energy in 5-30 psi gas to induce combustion air and mix the two for proper combustion in open or sealed-in premix burners.

Desired air/gas ratio is set with the air disc at high fire and is maintained reasonably throughout the turndown range, as long as combustion chamber pressure is fairly steady.

A gas orifice in the spud is carefully aligned with the machined throat in the body to ensure proper air inspiration and highest possible mixture pressures.

Inspirator capacity is affected significantly by the type of installation and pressure conditions within the combustion chamber:

Negative pressures (draft) increase inspirator capacity and retard flashback.

Positive pressures reduce capacity, and probability of flashback is greater.

At neutral furnace pressures, flashback normally will not occur at mixture pressures above 0.25"wc for natural gas.

Available turndown depends on mixture pressure, which in turn depends on gas and furnace pressures. Inspirators are primarily on-off devices.

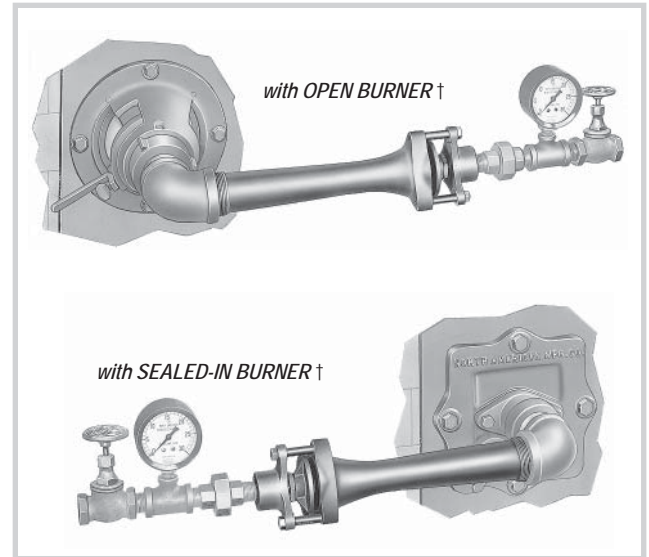

† Greater stability can be obtained by inserting pipe nipples, two pipe diameters

TABLE 1. Natural Gas capacities and Developed Mixture Pressures

(for 0.6 sp gr, natural gas, 1000 Btu/ft³, 10 ft³ air required/ft³ gas)

Gas Flow (cfh) in Bold Type, Mixture Pressures ("wc) in Light Type

Inspirator designation	gas pressure, psi						Burner size	Inspirator designation	gas pressure, psi						Burner size
	5	10	15	20	25	30			5	10	15	20	25	30	
3070-1 68 w/#68 drill	0.24	0.48	0.72	0.96	1.20	1.44	-1-A	3070-5 36 w/#36 drill	0.48	0.96	1.44	1.92	2.40	2.88	-5-B
3070-1 65 w/#65 drill	0.25	0.50	0.75	1.00	1.25	1.50	-1-B	3070-6 34 w/#34 drill	0.50	1.00	1.50	2.00	2.50	3.00	-6-A
3070-2 59 w/#59 drill	0.30	0.60	0.90	1.20	1.50	1.80	-2-A	3070-6 31 w/#31 drill	0.52	1.04	1.56	2.08	2.60	3.12	-6-B
3070-2 57 w/#57 drill	0.31	0.62	0.93	1.24	1.55	1.86	-2-B	3070-6 30 w/#30 drill	0.53	1.06	1.59	2.12	2.65	3.18	-6-C
3070-2 55 w/#55 drill	0.32	0.64	0.96	1.28	1.60	1.92	-2-C	3070-7 29 w/#29 drill	0.55	1.10	1.65	2.20	2.75	3.30	-7-A
3070-2 54 w/#54 drill	0.33	0.66	0.99	1.32	1.65	1.98	-2-D	3070-7 22 w/#22 drill	0.57	1.14	1.71	2.28	2.85	3.42	-7-B
3070-3 53 w/#53 drill	0.37	0.74	1.11	1.48	1.85	2.22	-3-A	3070-7 ¹¹/₆₄ w/#¹¹/₆₄ drill	0.59	1.18	1.77	2.36	2.95	3.54	-7-C
3070-3 52 w/#52 drill	0.40	0.80	1.20	1.60	2.00	2.40	-3-B	3070-8 3 w/#3 drill	0.62	1.24	1.86	2.48	3.10	3.72	-8-A
3070-4 50 w/#50 drill	0.41	0.82	1.23	1.64	2.05	2.46	-4-A	3070-8 C w/#C drill	0.64	1.28	1.92	2.56	3.20	3.84	-8-B
3070-4 46 w/#46 drill	0.43	0.86	1.29	1.72	2.15	2.58	-4-B	3070-8 J w/#J drill	0.66	1.32	1.98	2.64	3.30	3.96	-8-C
3070-4 44 w/#44 drill	0.45	0.90	1.35	1.80	2.25	2.70	-4-C	3070-8 ⁵/₁₆ w/#⁵/₁₆ drill	0.69	1.38	2.07	2.76	3.45	4.14	-8-D
3070-5 41 w/#41 drill	0.47	0.94	1.41	1.88	2.35	2.82	-5-A	3070-9 ²⁷/₆₄ w/#²⁷/₆₄ drill	0.74	1.48	2.22	2.96	3.70	4.44	-9

To order, specify:

3070-4 50

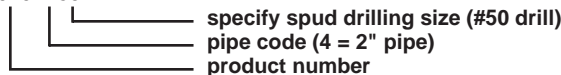

specify spud drilling size (#50 drill)
pipe code (4 = 2" pipe)
product number

TABLE 2. Factors for rich operation and for other gases

gas specifications			% air thru Inspirator	gas capacity factor	spud area and mixture press. factor
Btu/ft ³	sp gr	ft ³ air/ft ³			
800	0.54	5.8	100	0.68	1.36
			90	0.56	1.65
			80	0.47	2.00
			70	0.38	2.44
1000	0.6	10.0	90	0.83	1.21
			80	0.67	1.50
			70	0.53	1.90
1200	0.7	11.7	100	1.25	0.85
			90	1.03	1.02
			80	0.83	1.28
			70	0.66	1.60

TABLE 3. Inspirator Size for Multiple Premix Burners

Inspirator Selection. When more than one nozzle is used per inspirator, manifold must be designed for very low pressure drop to obtain listed inspirator ratings. Too much resistance reduces capacity and upsets air/gas ratios.

Burner size	number of burners						Burner size	number of burners				
	1	2	3	4	5	6		1	2	3	4	5
-0-A		3070-1 68	3070-1 65	3070-2 57	3070-3 53	3070-3 53	-4-A	3070-4 50	3070-6 34	3070-7 29	3070-7 22	3070-7 11/64
-0-B		3070-1 65	3070-2 57	3070-3 53	3070-3 52	3070-4 50	-4-B	3070-4 46	3070-6 31	3070-7 22	3070-7 11/64	
-0-C		3070-2 57	3070-2 54	3070-3 52	3070-4 50	3070-4 46	-4-C	3070-4 44	3070-6 31	3070-7 22		
-1-A	3070-1 68	3070-2 55	3070-3 53	3070-4 50	3070-4 46	3070-4 44	-5-A	3070-5 41	3070-7 29	3070-7 11/64		
-1-B	3070-1 65	3070-2 55	3070-3 52	3070-4 46	3070-5 41	3070-5 41	-5-B	3070-5 36	3070-7 22			
-2-A	3070-2 59	3070-3 53	3070-4 50	3070-4 44	3070-5 36	3070-6 34	-6-A	3070-6 34	3070-7 22			
-2-B	3070-2 57	3070-3 52	3070-4 44	3070-5 41	3070-6 34	3070-6 31	-6-B	3070-6 31	3070-7 11/64			
-2-C	3070-2 55	3070-4 50	3070-5 41	3070-5 36	3070-6 31	3070-6 30	-6-C	3070-6 30				
-2-D	3070-2 54	3070-4 46	3070-5 36	3070-6 34	3070-6 30	3070-7 29	-7-A	3070-7 29				
-3-A	3070-3 53	3070-4 44	3070-6 34	3070-6 31	3070-7 29	3070-7 22	-7-B	3070-7 22				
-3-B	3070-3 52	3070-5 41	3070-6 31	3070-7 29	3070-7 22	3070-7 11/64	-7-C	3070-7 11/64				

Multiple burners are not recommended because of flashback hazard in large manifolds.

Example: Non-standard selection. Inspirator to supply 80% air for 300 cfm of 20 psi 1000 Btu/ft³ gas.

In Table 2, read a 0.67 capacity factor and a 1.50 spud and mixture pressure factor. The required 300 cfm capacity × 0.67 = 201 cfm equivalent capacity. In the left half of Table 1, look down the 20 psi gas pressure column until you find a gas flow near 201 cfm. 192 cfm corresponds to a 3070-4 50 tentative inspirator size and drill designation and 1.64"wc tentative mixture pressure. The last number means #50 spud drill, which has 0.00385 sq. in. area (from any drill size table). Multiply this by the spud area factor, 0.00385 × 1.50 = 0.00578 sq. in. The next larger standard drill is #44 with 0.00581 sq. in. area. Therefore, specify a 3070-4 Inspirator with #44 spud drill. To find actual mixture pressure, multiply 1.64 × 1.50 = 2.46"wc.

For information on using 3070 Inspirators as high pressure air reducers (compressed air instead of a blower for low pressure air supply), refer to Sheet 3070-1.

For inspirators used with coke oven or producer gas, see Sheet 3080-1.

Inspirator designation	A	B	C	D	E	F	wt, lb
3070-1	1	3/8	2 7/16	7	9 7/16	3 3/16	2 1/4
3070-2	1 1/4	1 1/8	2 7/16	8 7/16	10 7/16	3 7/16	3
3070-3	1 1/2	1 1/2	2 9/16	10	12 9/16	3 7/8	5 1/2
3070-4	2	1 1/2	2 3/4	12	14 3/4	4 5/8	8
3070-5	2 1/2	3/4	2 3/4	14 13/16	17 9/16	4 7/8	11
3070-6	3	3/4	3 5/16	18 3/4	22 1/16	5 7/16	14 1/2
3070-7	4	1	3 9/16	21 7/16	25	6 5/16	23
3070-8	6	1	4 1/4	30	34 1/4	8 5/8	57
3070-9	8	1 1/2	6 3/16	36	42 3/16	11 1/4	110

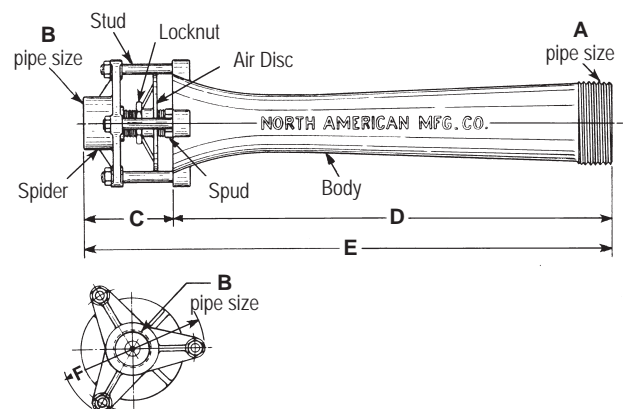

DIMENSIONS SHOWN ARE SUBJECT TO CHANGE. PLEASE OBTAIN CERTIFIED PRINTS FROM FIVES NORTH AMERICAN COMBUSTION, INC. IF SPACE LIMITATIONS OR OTHER CONSIDERATIONS MAKE EXACT DIMENSION(S) CRITICAL.

WARNING: Situations dangerous to personnel and property may exist with the operation and maintenance of a combustion equipment. The presence of fuels, oxidants, hot and cold combustion products, hot surfaces, electrical power in control and ignition circuits, etc., are inherent with any combustion application. Parts of this product may exceed 160F in operation and present a contact hazard. Fives North American urges compliance with National Safety Standards and insurance Underwriters recommendations, and care in operation.

Fives North American Combustion, Inc., 4455 East 71st Street, Cleveland, OH 44105 USA, Phone 216.271.6000
Fax 216.641.7852 email: fna.sales@fivesgroup.com • www.fivesgroup.com/fivesna