

4015 Pilot Sets are used to light large capacity Fives North American burners (Bulletin 4011 describes pilots for smaller burners). When properly installed, these premix pilots are unaffected by changes in main burner adjustment or furnace atmosphere or pressure conditions.

**PILOT TIPS**

Most 4025 pilot tips are spark-ignited, energized by a 6000-volt transformer; and most have threaded discharges (with "T" suffix) to fit sealed-in burners, by far the most common in industry today.

Manually ignited tips (with "M" suffix) are furnished with a lighter hole cap.

Special explosion resistant pilot tips are available on request. Consult Fives North American.

**PILOT SETS**

A 4015 set consists of tip, mixer, air valve, and gas cock. Mixers have inlet and outlet pressure taps, either of which can be used to cross-connect the pilot ratio regulator. This is desirable in some installations where pressure variations at the pilot tip could upset its air/fuel ratio. Several 4025 tips could be fed by a single higher capacity mixer, although this is not normally recommended with these larger pilots.

For information on pilot accessories refer to Supplement 4015-1 (regulators and solenoid valves) and Supplement 4015-2 (ignition transformers and cables).

Set number	capacity, Btu/hr 8 psi air 3.5"wc mixture pressure	PILOT SETS				Set weight
		Pilot Tip	Mixer	Air Valve	Gas Valve	
<b>SPARK IGNITED</b>						
<b>Threaded</b>						
4015-0-T	52 000	4025-0-T	3065-0-7	1122-0	1821-01	7 lb-10 oz
4015-2-T	123 000	4025-2-T	3065-2-12	1122-2	1821-1	12 lb
<b>Slip-Fit</b>						
4015-1	82 000	4025-1	3065-1-9	1122-1	1821-0	9 lb-10 oz
4015-2	123 000	4025-2	3065-2-12	1122-2	1821-1	12 lb
<b>MANUALLY IGNITED</b>						
<b>Threaded</b>						
4015-0-MT	52 000	4025-0-MT	3065-0-7	1122-0	1821-01	7 lb-10 oz
4015-2-MT	123 000	4025-2-MT	3065-2-12	1122-2	1821-1	12 lb
<b>Slip-Fit</b>						
4015-1-M	82 000	4025-1-M	3065-1-9	1122-1	1821-0	9 lb-10 oz
4015-2-M	123 000	4025-2-M	3065-2-12	1122-2	1821-1	12 lb

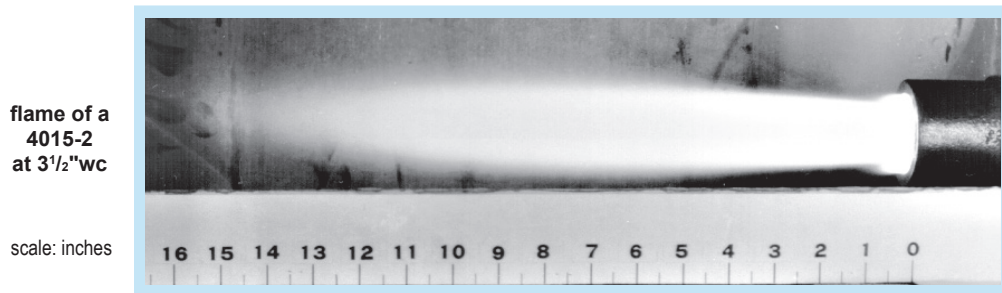

**PILOT TIPS**

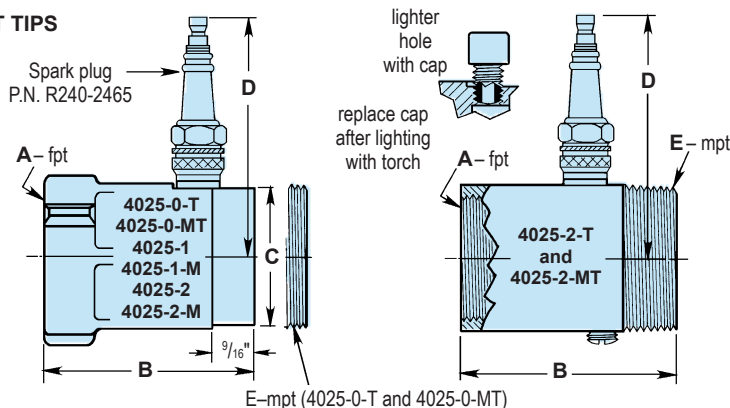

Pilot Tip number	dimensions in inches				
	A	B	C	D	E
4025-11	2 <sup>23</sup> / <sub>32</sub>	1 <sup>23</sup> / <sub>32</sub>	3 <sup>1</sup> / <sub>16</sub>	-	-
4025-21 1/4	2 <sup>27</sup> / <sub>32</sub>	1 <sup>31</sup> / <sub>32</sub>	3 <sup>3</sup> / <sub>16</sub>	-	-
4025-0-T	3/4	2 <sup>23</sup> / <sub>32</sub>	-	3	1 1/4
4025-2-T	1 1/4	3 1/16	-	3 3/16	1 1/2
4025-1-M	1	2 <sup>23</sup> / <sub>32</sub>	1 <sup>23</sup> / <sub>32</sub>	-	-
4025-2-M	1 1/4	2 <sup>27</sup> / <sub>32</sub>	1 <sup>31</sup> / <sub>32</sub>	-	-
4025-0-MT	3/4	2 <sup>23</sup> / <sub>32</sub>	-	-	1 1/4
4025-2-MT	1 1/4	3 1/16	-	-	1 1/2

**PILOT MIXERS**

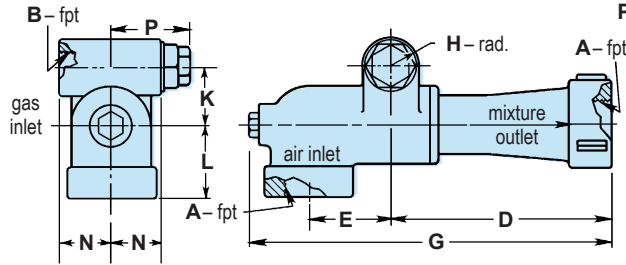

Mixer designation	dimensions in inches									wt,	
	A	B	D	E	G	H	K	L	N	P	lb
3065-0	3/4	1/2	4 1/32	1 3/4	7 9/32	5/8	1 3/16	1 21/32	1 1/4	2	4
3065-1	1	3/4	4 1/8	1 13/16	7 7/16	3/4	1 3/8	1 7/8	1 9/32	2 1/32	5
3065-2	1 1/4	1	5 7/8	2 1/16	9 5/8	7/8	1 21/32	2 1/32	1 15/32	2 7/32	7

3065 Mixer rod size (stamped on nut) should be #7 for 4025-0 Pilot, #9 for 4025-1, #12 for 4025-2.

**GAS COCKS**

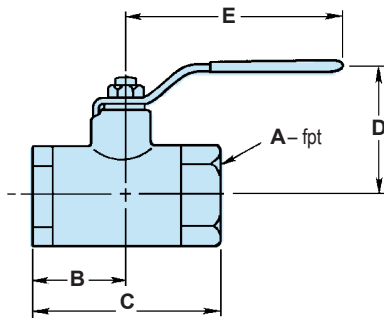

Valve designation	dimensions in inches					wt, lb
	A	B	C	D	E	
1821-01	1/2	1 1/8	2 1/4	1 13/16	3 7/8	0.6
1821-0	3/4	1 1/2	3	2 1/8	4 7/8	1 1/4
1821-1	1	1 11/16	3 3/8	2 1/4	4 7/8	1 3/4

**AIR VALVES**

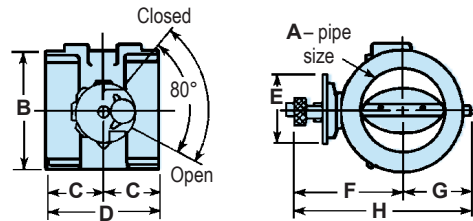

Valve designation	dimensions in inches								wt, lb
	A	B	C	D	E	F	G	H	
1122-0	3/4	2 1/16	1 3/16	2 3/8	3	2 3/4	1 3/16	3 15/16	2
1122-1	1	2 1/16	1 3/16	2 3/8	3	2 3/4	1 3/16	3 15/16	2
1122-2	1 1/4	2 5/16	1 1/4	2 1/2	3	2 13/16	1 5/16	4 1/8	2 1/4

DIMENSIONS SHOWN ARE SUBJECT TO CHANGE. PLEASE OBTAIN CERTIFIED PRINTS FROM FIVES NORTH AMERICAN COMBUSITON, INC. IF SPACE LIMITATIONS OR OTHER CONSIDERATIONS MAKE EXACT DIMENSION(S) CRITICAL.

**INSTALLATION**

1. Pilot air supply must be at constant pressure, i.e. taken from main air manifold between combustion air blower and main air control valve.
2. Pilot gas supply must be taken upstream of main gas regulator and shutoff valves. It may be necessary to install a pressure reducing regulator in the pilot gas line. See Supplement 4015-1.
3. 7218 Pilot Gas Regulators must be mounted with spring housing down. 7350 Pilot Gas Regulators may be mounted in any position. See Supplement 4015-1 (Pilot Accessories).
4. To avoid problems caused by dirt in the pilot tip, install main burner so pilot port is located between 9 and 3 o'clock, (above the horizontal C).
5. While pilot tip may be screwed directly into its mixer, a minimum of 5 pipe diameters is recommended between mixer and tip. If there is an elbow between mixer and tip, there **must** be 5 pipe diameters straight pipe between elbow and tip.
6. Use hi-temp anti-seize compound on threaded pilot tips and hand tighten into burner. Lightly wrench tighten only if firing against abnormally high positive pressure.
7. When installing pilot tip, orient spark plug or lighter hole so it is easily accessible.
8. Installation of a union between mixer and tip will facilitate removal of tip for cleaning.

**PRESSURE REQUIREMENTS**

1. Minimum recommended air pressure at pilot mixer inlet is 4.0 osi.
2. Minimum gas pressure at pilot regulator inlet for a cross-connected system should be 2 osi higher than loading pressure (air or air/gas mixture).
3. Minimum gas pressure at pilot regulator inlet for an atmospheric (zero gas pressure) system is 2 osi.
4. For maximum pilot regulator inlet pressure, see Supplement 4015-1.

**LIGHTING**

1. Close all manual pilot and main gas supply valves.
2. Make sure all fans and blowers are running and combustion chamber has been purged with a minimum of (4) changes of atmosphere.
3. Adjust main burner's air control valve for low fire air pressure (if applicable).
4. Set air pressure to the pilot mixer inlet at 6-8 osi above combustion chamber pressure. This will result in a 3-4"wc mixture pressure **after** pilot is lit.
5. Make sure pilot mixer gas adjustment is fully closed (CW).
6. Energize ignition and pilot gas solenoid valve.
7. Open pilot gas cock.
8. Counting the number of turns, slowly open (CCW) mixer adjustment, noting setting at which pilot initially lights.
9. Continue opening adjustment until pilot flame becomes unstable, losing its sharp inner cone.
10. Return valve to a position midway between settings determined in steps 8 and 9.
11. De-energize ignition to make sure pilot remains stable without spark. Readjust if necessary.
12. Energize ignition and pilot solenoid simultaneously several times to verify repeatable ignition.

**NOTES**

1. Spark plug ground electrode must be bent 45° resulting in a 0.09"-0.10" gap.
2. If pilot will not light, check for spark at the plug and gas at the mixer. If both are present, remove and clean pilot tip. Make sure all piloting ports are clean: Plugging of one hole can prevent lighting.

**WARNING:** Situations dangerous to personnel and property may exist with the operation and maintenance of any combustion equipment. The presence of fuels, oxidants, hot and cold combustion products, hot surfaces, electrical power in control and ignition circuits, etc., are inherent with any combustion application. Parts of this product may exceed 160F in operation and present a contact hazard. Fives North American Combustion, Inc. urges compliance with National Safety Standards and insurance Underwriters recommendations, and care in operation.

Fives North American Combustion, Inc. - 4455 East 71st Street - Cleveland, OH 44105 USA - Phone 216.271.6000  
Fax 216.641.7852 - email: fna.sales@fivesgroup.com - www.fivesgroup.com/fivesna