

- ① Radial gas--Increasing radial gas flow (with flame adjustment screw **S**) shortens flame.
- ② Forward gas--Increasing forward gas flow (with flame adjustment screw **L**) lengthens flame.
- ③ Jet gas--used to maintain flame definition as input is reduced.

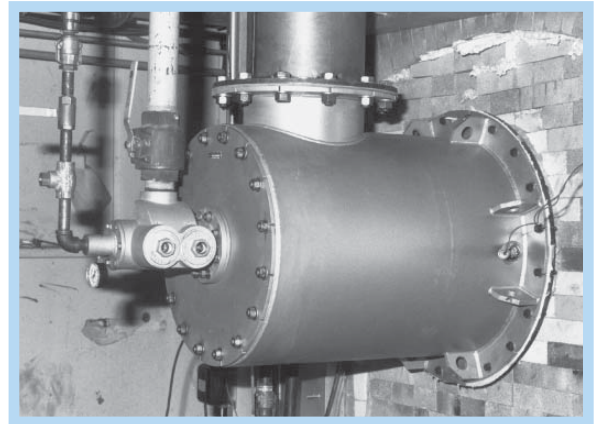

Manual flame adjustment screws, as shown here on the burner gas connection, adjust flame shape.

- Range 3 to 68 million Btu/hour
- For furnaces, boilers, process heaters, and dryers up to 2000 F
- Standard Low NOx capability
- Fits the flame to the combustion chamber
- Distributes the heat where it's needed
- High turndown capabilities

4384 Fuel Directed Magna-Flame Burners are used with ambient temperature combustion air on a wide variety of furnaces operating up to 2000 F. Fuel directed principles enable these burners to vary flame configuration from approximately 750 000 Btu/hr per foot of length to 2 000 000 Btu/hr per foot. User can manually select optimum flame shape with the flame adjustment, which is an integral part of the gas connection. Refer to Bulletins 4472 and 4482 for Fuel Direct models operating with preheated combustion air and at higher furnace temperatures.

Fuel Directed Burner bodies and backplates are fabricated of heavy gauge welded steel. Internal parts include a front refractory ring, alloy flame stabilizer, and an investment cast A330SST nozzle.

Burners use gas pressure to create a flame shape and heat pattern that is most advantageous for the installation they are firing. A controlled flame shape is **desirable** in almost any application--it is **essential** in many to realize optimum furnace performance.

OPERATION

Burners are designed for a nominal 6"wc air pressure. Stoichiometric firing at this nominal capacity will result in a fuel pressure requirement of 8 psig at the burner. Operation is quiet and the burner is stable over a wide range of air/gas ratios ranging from 30% fuel rich to 1000% excess air at 6"wc. Stoichiometric turndown is 10:1 with 6"wc main air pressure. In installations with high excess air rates, FGR, or preheated air, select burner size based upon heat input. Air pressure can then exceed 6"wc, but not beyond 10"wc. For multiple burner installations requiring high turndown capability, air inlet orifices should be considered to ensure adequate header pressure for uniform air distribution at low inputs.

Standard design is for 8 psig gas pressure at the burner; however a 2 psig option is available in sizes up to -20 if gas pressure is limited. Be sure to specify the LO option when ordering the 2 psig model.

A constant gas jet at 8 psi and 5% of maximum capacity maintains flame definition as input is reduced.

A low fire start is required at 1"wc or less main air pressure.

COMBUSTION AIR CAPACITIES, scfh
long flame mode

Capacities are reduced up to 10% in short flame mode.

Burner designation	air pressure		
	0.06"wc*	3"wc	6"wc†
4384-8	4 070	28 600	40 700
4384-9	7 100	50 800	71 500
4384-10-A	8 900	63 000	89 200
4384-10-B	11 300	80 000	113 000
4384-12	16 000	114 000	160 000
4384-14	20 000	142 000	200 000
4384-16	26 000	187 000	264 000
4384-18	33 000	238 000	337 000
4384-20	42 000	296 000	419 000
4384-22	51 000	361 000	509 000
4384-24	61 000	430 000	608 000
4384-26	75 000	530 000	750 000

* min. air rate † recommended press. (See "Operation".)

RANGE OF FLAME LENGTHS and DIAMETERS
(2000 F Furnace) in feet with 8 or 2 psig gas

Air/gas ratio set for 10% excess air.

Burner designation	SHORT FLAME (10% reduced capacity) air pressure		LONG FLAME (full capacity) air pressure		FLAME DIA. (full capacity) long or short
	3"wc		6"wc		
	3"wc	6"wc	3"wc	6"wc	
4384-8	3	4	8	14	2
4384-9	3 1/2	4 1/2	9	15	2
4384-10-A	3 1/2	5	10	16	2.5
4384-10-B	4 1/2	6	12	18	2.5
4384-12	5	7	14	20	2.5
4384-14	5 1/2	8	15	24	3
4384-16	7	10	20	30	3
4384-18	8 1/2	12	25	34	3.5
4384-20	10 1/2	15	30	40	3.5
4384-22	13	18	32	45	4
4384-24	15	20	40	50	4
4384-26	19	24	49	60	4.5

‡ Flame lengths will be longer in a lower temperature furnace.

CONTROL

Mass flow control is recommended. Standard 4384 Fuel Directed® Burners have a single gas connection with internal radial/forward gas adjustment for flame shaping.

Main and center jet gas should be supplied to the burner at the same time. See flow control schematic.

PILOT and FLAME SUPERVISION

Burners are ignited with a gas-boosted pilot. Pilot air pressure must be at least 10"wc, and pilot regulator must be cross-connected to the pilot air line (see Sheet 4014).

If flame supervision is used, pilot must be of the interrupted type. UV flame detection is recommended (using an 883_-D adapter).

LOW NO_x

The 4384 Fuel Directed Burner is an inherently Low NO_x burner. In conjunction with other NO_x reducing features, it is capable of meeting emission limitations for new or retrofit applications in environmentally sensitive installations. Contact your North American Mfg. Sales Engineer for specific applications.

BURNER TILE CONSTRUCTION

4384 Burners do not include a tile. Tunnel shapes and recommended installation is shown on Dimensions & Installation 4384.

OTHER FUELS

For other gaseous fuels and oils, contact your North American Sales Engineer.

Typical Single Burner Fuel Directed Flow Control Schematic

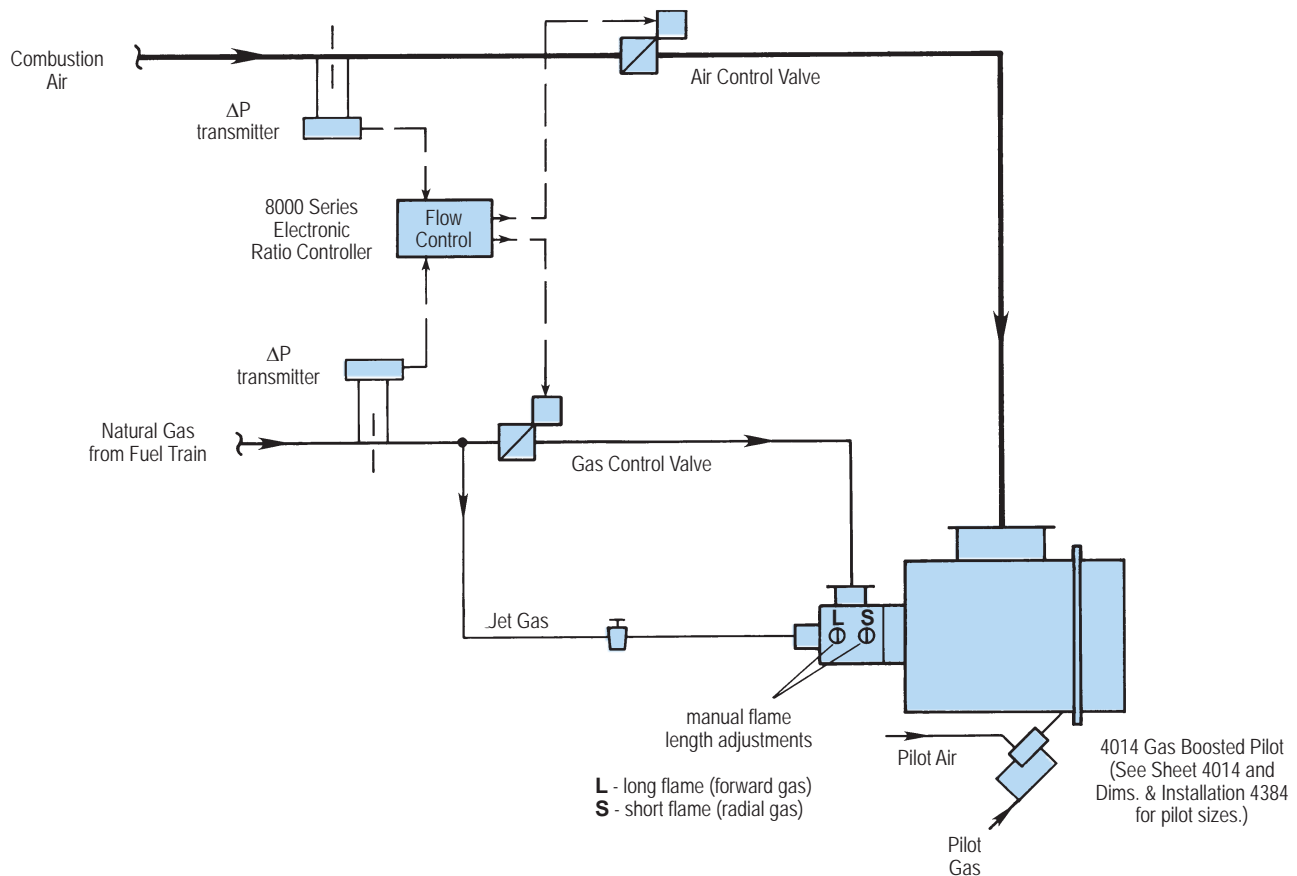

BURNER ADJUSTMENTS

1. The flame length adjusters are located on the side of the gas inlet connection. Initially set both the short (S) and the long (L) flame adjustment screws equally open. (Fully close both adjusters by turning them clockwise, then open 2 turns.)
2. Establish pilot flame. See Sheet 4014 for instructions.
3. Establish main flame. If main flame cannot be established, open (S) and (L) flame adjustment screws equally until a flame is established.
4. With an established flame, drive the system to high fire. Set air/fuel ratio.

Using the (S) and (L) flame adjustment screws, make the desired flame length adjustments. If high fire gas flow cannot be reached, open the (S) and (L) flame length adjustment screws equally until the proper gas flow is obtained. Correct air/fuel ratio as required.

5. Drive the system to low fire. Set air/fuel ratio. If used, adjust jet gas valve to improve the low fire flame definition.
6. Drive the system to high fire and verify flame length and air/fuel ratio.

To order, specify: 4384-(code for pipe size)-(A, if applicable) / (LO for 2 psig model) Burner Complete (specify Arrangement Designators-- see Dimensions & Installation 4384).

Examples: 4384-10-A 10" Burner Complete with arrangement 3a1
4384-12/LO 12" Low Gas Pressure Burner Complete with arrangement 1c3

WARNING: Situations dangerous to personnel and property may exist with the operation and maintenance of any combustion equipment. The presence of fuels, oxidants, hot and cold combustion products, hot surfaces, electrical power in control and ignition circuits, etc., are inherent with any combustion application. Parts of this product may exceed 160F in operation and present a contact hazard. Fives North American urges compliance with National Safety Standards and insurance Underwriters recommendations, and care in operation.

Fives North American Combustion, Inc., 4455 East 71st Street, Cleveland, OH 44105 USA, Phone 216.271.6000
Fax 216.641.7852 email: fna.sales@fivesgroup.com • www.fivesgroup.com/fivesna