

## **TEMPEST GAS BURNER INSTALLATION INSTRUCTIONS**

### **Refractory Wall Installation**

1. If the burner/tile is supported by a metal shelf fastened to the inside of the furnace wall, flanged burners may be bolted directly to the furnace shell.
2. If the burner/tile is not supported by a metal shelf, but sits on a refractory wall that will shift in relation to the furnace shell as the furnace expands, do not bolt the burner to the shell, but allow it to move with the wall otherwise the tile will shear.

**Note:** The opening for the burner in the furnace shell must provide sufficient clearance to accommodate both the lateral and vertical movement of the burner as the wall shifts.

3. The burner/tile mounting assembly may be installed in the furnace wall with or without cement. However, if the burner is not cemented, pack any openings at the top or sides of the burner with refractory fiber to prevent cold air infiltration created by the high velocity of the Tempest burner.

**Note:** The Tempest burner/tile must rest on a hard surface. Use cement between the burner and this surface to provide uniform support and to seal against air leakage.

### **Fiber Wall Installation**

4. Burners must be bolted directly to the furnace shell for support. (The 4442—F flanged version is required.)
5. Burner/tiles must either be supported on a steel shelf fastened to the inside of the furnace shell, or with an optional burner/tile jacket which must be specified when ordering the burner.

### **General**

6. Do not install the burner mounting in the furnace wall beyond its mounting ears.
7. If a Tempest burner is installed in a wall thicker than 16", its discharge velocity will diminish significantly unless the wall opening is enlarged accordingly.
8. Individual 7216 or 7218 Air/Gas Ratio Regulators should be installed on each burner.
9. The limiting orifice gas valve should be installed as close to the burner as possible, preferably mounted on a short nipple.
10. All other controls should be located as close to the burner as is practical.
11. Always install flexible air and gas connections at the burner to prevent damage from expansion of the furnace and the piping.

---

## **ACCESSORIES AND REPLACEMENT PART INFORMATION**

---

### **1. Pressure Taps**

All burner pressure taps are  $\frac{1}{8}$ " fpt, and identified by the following codes: UA = upstream air, DA = downstream air, UG = upstream gas, DG = downstream gas. The pressure tap locations on 4442-5, -6 and -7 are different from the illustration shown on page 4. 4442-0 and 4442-4-S burners do not have an integral air orifice. For pressure tap valves and hose connectors, order 4442-PK (one set per burner).

### **2. Replacement Parts**

**Gasket:** The 4442 gasket is more than a sealing device between the body and mounting. It performs an integral function in the burner's operation. As such, it **cannot** be replaced with fiber rope or a homemade gasket. Because the gasket cannot be reused if the burner is taken apart for maintenance, it is essential that you keep spare gaskets in stock. **Always install a new gasket!**

**Tiles:** 4442 tiles seldom need replacement, but do require special consideration. It takes a considerable amount of mortar to assemble the burner mounting and tile. As the mortar contains a significant amount of water, it requires (7) days to dry or it could form steam and create a passage for leakage of furnace gases. To avoid this problem, there are three choices: a) Cement a new tile into the mounting and air dry for seven days before installing in the furnace. b) Return the mounting to North American for installation of a new tile. There will be a charge in addition to the cost of the tile. Contact your local NA office for return procedure. c) Purchase a new mounting plate and tile assembly. We recommend that you keep a spare in stock.



## INITIAL LIGHTING PROCEDURE

1. Close all manual gas valves (Items **A**, **F**, **H**, **J** and **N**) and the UV cooling air valves (Item **S**). Make sure the needle valve under the cap of item **N** is closed.
2. Open the main air valve (**P**) and all balancing valves (**Q**).
3. Open the furnace doors. Start the combustion air blower.
4. Adjust the motor/valve linkage in Block 1 and/or Block 2 as required.
5. Energize the controls and run the system through the purge cycle.
6. With the main air control valve (**P**) at high fire, and the 3-way solenoid valve (**V**) in the vent position [no signal to the ratio regulator (**G**)]:
  - a) Open the main gas valve (**A**).
  - b) Open the bypass gas valve (**J**).
  - c) Open the bypass solenoid gas valve (**L**).
  - d) Open only one bypass gas valve (**N**), including the internal needle valve.
  - e) Adjust the bypass gas regulator (**K**) for 16 psi outlet pressure.
  - f) Close the bypass gas solenoid (**L**).
  - g) Close the bypass gas valve (**N**), including the internal needle valve.
7.
  - a) Energize the igniter.
  - b) Open the bypass solenoid gas valve (**L**).
  - c) Open only one bypass gas valve (**N**), leaving the internal needle valve closed.
  - d) Slowly open the internal needle valve in (**N**) until the burner lights.
  - e) De-energize the igniter and bypass gas solenoid (**L**).
8.
  - a) Energize the bypass solenoid (**L**).
  - b) Energize the igniter.
  - c) If the burner does not light, increase the opening of the internal needle valve in valve (**N**) and repeat the sequence.

**Note:** The burner must light when the gas is turned on before the ignition.

  - d) Purge the combustion chamber after each attempt at ignition.
9. Repeat steps 7 and 8 for all burners.
10. When all burners are lit, switch the 3-way solenoid air valve (**V**) to send the air impulse to the ratio regulator (**G**).
11. Open the manual reset gas shutoff valve (**C**). The vent valve (**D**) should close, and the blocking valve (**E**) should open.
12.
  - a) Open one burner gas shutoff valve (**F**).
  - b) Slowly open the limiting orifice gas valve (**H**) until the burner lights and the required gas flow is achieved.
13. Repeat step 12 for the remainder of the burners.
14. Drive the main air valve (**P**) to low fire and adjust the ratio regulator (**G**) for a stable low fire.
15. Re-check burner ignition at high fire with no impulse air to the ratio regulator.
16. Turn on the UV cooling air and adjust the needle valves (**S**) for adequate air flow.
17. Close the furnace doors.

## PARTS LIST

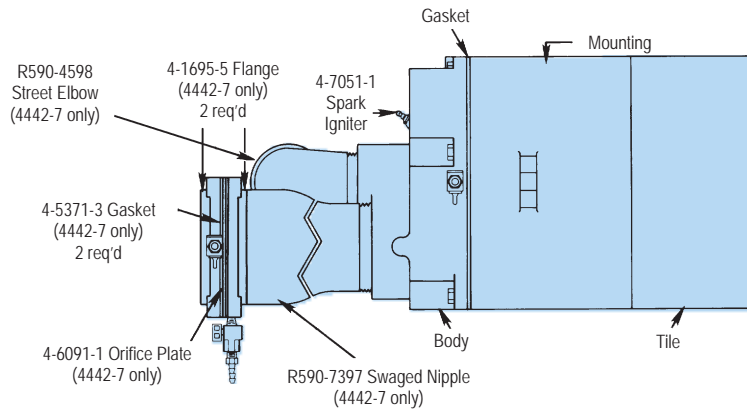

Part Name	4442-0	4442-1	4442-2	4442-3	4442-4	4442-4-S	4442-5	4442-6	4442-7
Body	4-10334-1	4-5582-12	4-5582-13	4-5582-14	4-5582-15	4-5582-16	4-5782-9	4-5782-10	4-6097-4
Gasket	4-9083-1	4-5896-1	4-5896-1	4-5616-2	4-5616-2	4-5616-2	4-5853-4	4-5854-4	4-13912-1
Mounting & Tile Assembly	4-7848-57	4-7848-1	4-7848-2	4-7848-3	4-7848-4	4-7848-4	4-7848-5	4-7848-6	4-7848-7
Mounting	4-5743-3	4-5743-3	4-5743-3	4-5743-3	4-5743-3	4-5743-3	4-6724-2	4-6724-2	4-13913-1
Tile	4-8634-1	4-7483-1	4-5744-2	4-5745-3	4-5741-2	4-5741-2	4-6219-2	4-6220-1	4-6096-1
Observation Port	8790-0	8790-0	8790-0	8790-0	8790-0	8790-0	8790-0	8790-0	8790-0
Petcock Kit	4442PK	4442PK	4442PK	4442PK	4442PK	4442PK	4442PK	4442PK	4442PK
Flanged Mounting (4442- F)	4-7474-1	4-7474-1	4-7474-1	4-7474-1	4-7474-1	4-7474-1	4-7475-1	4-7475-1	4-14884-1

# DIMENSIONS

in inches

Test cock locations vary on larger sizes.

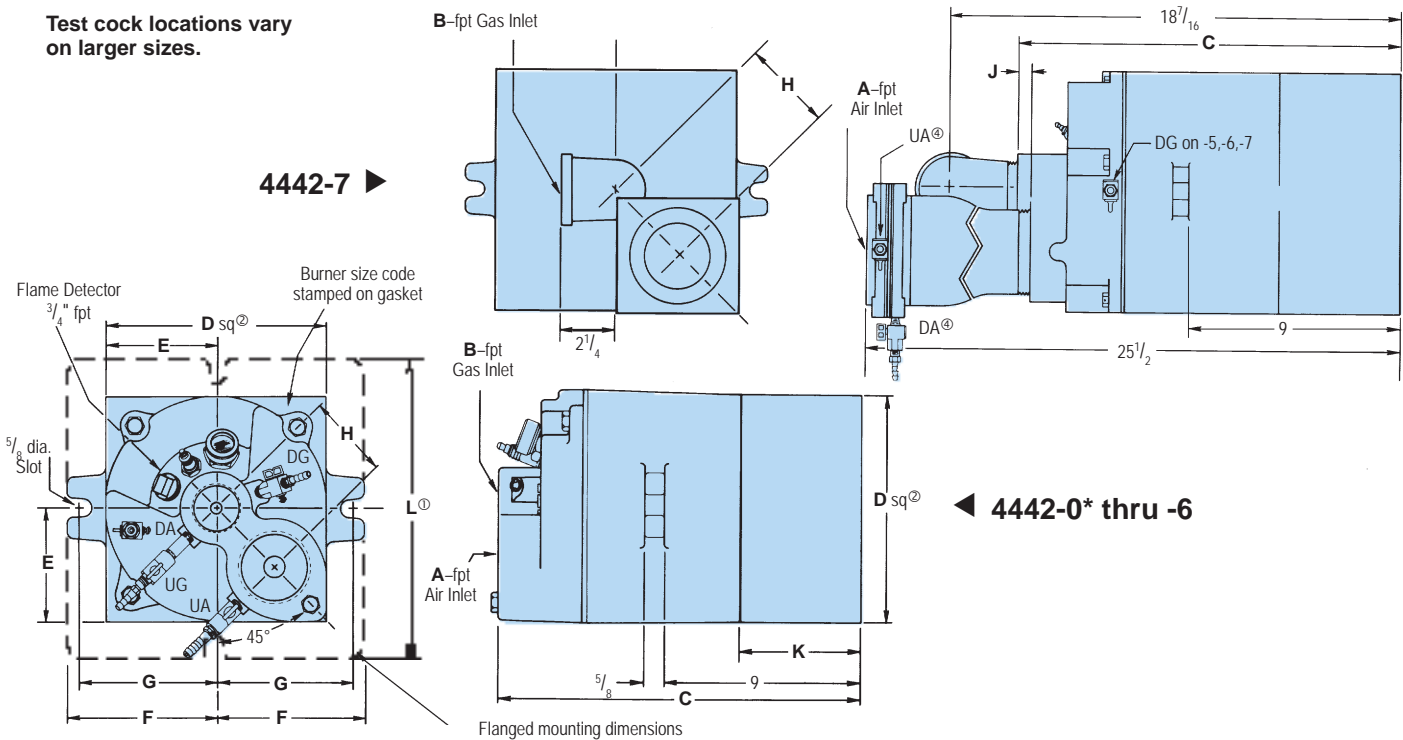

\* 4442-0 and 4442-4-S do not have an integral air orifice.

DIMENSIONS SHOWN ARE SUBJECT TO CHANGE. PLEASE OBTAIN CERTIFIED PRINTS FROM FIVES NORTH AMERICAN COMBUSTION, INC. IF SPACE LIMITATIONS OR OTHER CONSIDERATIONS MAKE EXACT DIMENSION(S) CRITICAL.

Burner designation <sup>①</sup>	dimensions in inches										burner complete weight, lb		flame rod length <sup>③</sup>	
	A	B	C	D sq <sup>②</sup>	E	F	G	H	J	K	L <sup>①</sup>	4442		4442- -F
4442-0	3/4	3/8	14 1/4	7 1/2	3 3/4	5	4 1/2	2 3/4	-	6 1/2	10	75	80	8 1/4
4442-1	1	3/4	14 1/4	7 1/2	3 3/4	5	4 1/2	2 3/4	-	6 1/2	10	75	80	8 1/4
4442-2	1 1/4	3/4	14 1/4	7 1/2	3 3/4	5	4 1/2	2 3/4	-	6 1/2	10	75	80	8 1/4
4442-3	1 1/2	3/4	14 1/4	7 1/2	3 3/4	5	4 1/2	2 3/4	-	6 1/2	10	75	80	8 1/4
4442-4	2	1	14 1/4	7 1/2	3 3/4	5	4 1/2	2 3/4	-	6 1/2	10	75	80	8 1/4
4442-4-S	2	1	14 1/4	7 1/2	3 3/4	5	4 1/2	2 3/4	-	6 1/2	10	75	80	8 1/4
4442-5	2 1/2	1 1/4	15 15/16	10	5	6 1/4	5 3/4	3 5/8	9/16	5 1/4	12 1/2	125	135	7 9/16
4442-6	3	1 1/2	15 15/16	10	5	6 1/4	5 3/4	3 5/8	9/16	5 1/4	12 1/2	125	135	8
4442-7	4	2	15 15/16	10	5	6 1/4	5 3/4	3 5/8	9/16	5 1/4	12 1/2	140	150	7 3/4

## Flanged Mounting

To specify, add -F as 3rd term (or add F to existing 3rd term).

Example: 4442-4-F Flanged Tempest® Burner Complete

- ① All dimensions except "L" apply to both standard and flanged (4442- -F) Tempests. "L" is flange dimension for 4442- -F.
- ② Opening in steel furnace shell should be about 1/2" larger than dimension D to allow for fillets and draft on mounting.
- ③ From outer boss of the flame rod connection, contact North American Mfg. Co. for flame rod performance.
- ④ Air orifice location for 4442-7 only.

For information on Tempest Venturi Tiles, see Sheet 4442-4.

**WARNING:** Situations dangerous to personnel and property may exist with the operation and maintenance of any combustion equipment. The presence of fuels, oxidants, hot and cold combustion products, hot surfaces, electrical power in control and ignition circuits, etc., are inherent with any combustion application. Parts of this product may exceed 160F in operation and present a contact hazard. Fives North American urges compliance with National Safety Standards and insurance Underwriters recommendations, and care in operation.

Fives North American Combustion, Inc., 4455 East 71st Street, Cleveland, OH 44105 USA, Phone 216.271.6000  
Fax 216.641.7852 email: fna.sales@fivesgroup.com • www.fivesgroup.com/fivesna