

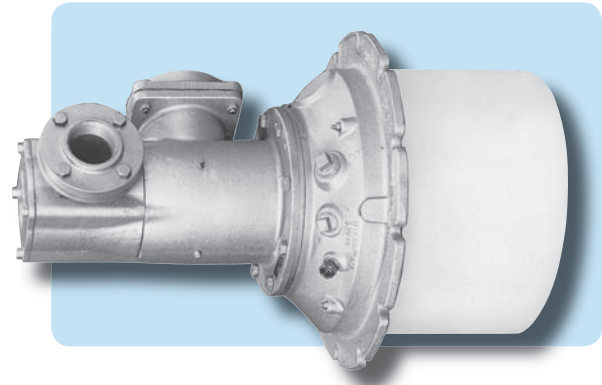

- Gas-only burner
- Conventional forward flame pattern
- 1.5 to 26 million Btu/hr
- Chambers up to 2400F (with alloy nose)
- Low Btu fuels (500 Btu/ft<sup>3</sup> or higher)



4514 FIRE•ALL are nozzle-mix, sealed-in burners used for many years on high temperature furnaces such as those for forging steel, melting aluminum or brass, and reheating steel bars or ingots...and on low temperature ovens and air heaters.

Their construction allows maximum efficiency through close control of air/gas ratio, furnace atmosphere, and furnace pressure--all contributing to better product quality.

**OPERATION**

**Control:** Normally, air primary with a cross-connected, pressure-balance regulator. For maximum turndown, use a 7216 (biased) Regulator, or throttle gas only.

To protect burner from heat damage, do not set air pressure below 1 osi in a 1900 F furnace, or below 2 osi at 2200 F (whether gas is on or off).

**Gas pressure requirement:** About 1 osi at the burner for natural gas on stoichiometric ratio; about 1/5 of the air pressure for coke oven gas.

**Lighting:** See 4514 Dimension Sheet for recommended premix pilot tips.

**Flame Supervision.** Flame safeguards are recommended for all installations. An ultraviolet cell will monitor pilot or main flame. For maximum safety, Fives North American urges **interrupted** pilots when flame safeguards are used--pilots should be on only for a preset ignition period (usually 15 seconds), after which flame supervision detects main fire only. Adapters for mounting flame detection devices on 4514 Burners are tabulated on Bulletin 8832.

**Tile/Installation.** Burner tiles are cast refractory rated for 2800 F furnace temperature. They are replaceable in the field, except for the 4514-10 whose mounting must be returned to the factory for tile replacement (or purchase a spare mounting plate with a tile cast onto it).

Burner tiles should be supported securely in the furnace wall by a layer of castable refractory (not insulation) at least 9" thick all around the tile, extending back to the furnace shell and securely anchored to it. (See Supplement DF-M1.)

**Jacketed Tile** options are available for applications where the tile is not supported by furnace refractory. Jackets are available in three different metals and have maximum temperature ratings for each. They must be protected with sufficient insulation so as not to exceed rated temperature. The maximum temperature rating for jacket metals depends upon frequency of heat-up/cool-down cycles. As an example, batch annealing furnaces that are heated and cooled every day should use the "intermittent exposure" ratings. Continuous annealing furnaces that remain at the same temperature for months at a time, can use the higher "continuous" rating.

Designation	Jacket Metal	Continuous max.temp.	Intermittent exposure
4514- -LC	carbon steel	700 F	700 F
4514- -L4	304 stainless	1600 F	1500 F
4514- -L9	309 stainless	1900 F	1800 F

**COMBUSTION AIR CAPACITIES**

scfh

(for Btu/hr, multiply by 100)

Burner designation	air pressure drop across the burner in osi								approximate flame length stoichiometric ratio	available excess air ratio setting
	0.1	1	5	6	8	12	16	24		
4514-6	1 180	3 710	8 300	9 100	10 500	12 900	14 900	18 200	4 1/2'	300%
4514-7	1 930	6 100	13 600	15 000	17 200	21 000	24 400	29 900	5'	650%
4514-8-A	3 350	10 600	23 700	26 000	30 000	36 700	42 400	51 900	8'	450%
4514-8-B	5 550	17 600	39 200	43 000	49 600	60 500	70 000	85 700	9'	250%
4514-9	11 600	36 600	82 000	89 500	104 000	127 000	146 000	179 000	16'	700%
4514-10	17 300	54 500	122 000	135 000	154 000	189 000	218 000	267 000	19'	350%

**Burner Nose** options are available for sizes shown below and can be specified in the product number. The burner nose establishes main combustion air flow and influences flame propagation. Nose material is either cast iron that is suitable for cold air applications up to 1800F, or cast stainless alloy for preheated air (maximum 700F) applications up to 2400F.

Mat'l	Cap'y	-6	-7	-8A	-8B	-9	-10
Cast iron	1.0	√	√	√	√	√	√
Cast Alloy	1.0	√	√	√	√	√	√
Cast iron	1.1		√	√	√	√	√
Cast Alloy	1.1		√	√	√	√	√
Cast iron	1.2			√	√	√	√
Cast Alloy	1.2			√	√	√	√
Cast iron	1.3			√	√	√	√
Cast Alloy	1.3			√	√	√	√

The product designation 1.0 represents standard main air capacity shown on page 1. Use of an extra capacity burner nose will result in either more air at 16 psi or standard air flow at lower pressure. Extending the capacity of the burner by increasing air pressure beyond 16 psi, or using the extra capacity nose, is acceptable for most gas applications. Specific applications involving low Btu fuels and extra capacity should be reviewed with Fives North American.

**CLEARANCE DIMENSIONS** (for details see Dimensions 4514)

Burner designation	Dimensions in inches							Wt. lb
	A†	B	C	D	E	F	G	
4514-6	3	2	10 <sup>3</sup> / <sub>8</sub>	19 <sup>1</sup> / <sub>2</sub>	14 <sup>15</sup> / <sub>16</sub>	9	15	190
4514-7	4	2 <sup>1</sup> / <sub>2</sub>	11 <sup>3</sup> / <sub>8</sub>	20 <sup>1</sup> / <sub>2</sub>	16 <sup>7</sup> / <sub>8</sub>	8 <sup>7</sup> / <sub>8</sub>	16	215
4514-8-A	6	2 <sup>1</sup> / <sub>2</sub>	12 <sup>3</sup> / <sub>8</sub>	22 <sup>3</sup> / <sub>4</sub>	22 <sup>3</sup> / <sub>8</sub>	10	17 <sup>3</sup> / <sub>4</sub>	320
4514-8-B	6	3	13 <sup>1</sup> / <sub>2</sub>	24	25 <sup>15</sup> / <sub>16</sub>	12 <sup>7</sup> / <sub>8</sub>	19	420
4514-9	8	4	16	28	30 <sup>13</sup> / <sub>16</sub>	13 <sup>7</sup> / <sub>16</sub>	23	740
4514-10	10	6	20 <sup>1</sup> / <sub>2</sub>	32 <sup>1</sup> / <sub>2</sub>	35 <sup>1</sup> / <sub>8</sub>	13 <sup>3</sup> / <sub>8</sub>	27 <sup>1</sup> / <sub>2</sub>	960

†SW connection standard for -9 and -10 only.

Also, when firing extra capacity, the combustion air flow velocity within the supply piping, and associated pressure loss, can be excessive for some burners. The -8B, -9 and -10 products when operated at 1.2 or 1.3 capacity will develop high pipe velocity based on the burner's air connection size. As an alternative to increasing blower pressure, an oversized air inlet can be purchased separately for these size burners. The connections are SW-type (slip-on sleeve or welded construction) and are one pipe size larger than the standard supply. Nose and oversize air connection part numbers can be found in supplement literature (see Parts List and Burner Options documents).

**Additional** options are available for the 4514 burner but require consultation with Fives North American for application and ordering information. See Sheet 6514-3 for an overview of burner options.

**DUAL FUEL**

6514 FIRE•ALL Burners are available for oil standby or combination gas and oil firing. See Bulletin 6514. 4514 Gas Burners can be converted to 6514 Dual-Fuel™ Burners with an appropriate conversion kit (see Parts List 4514-2).

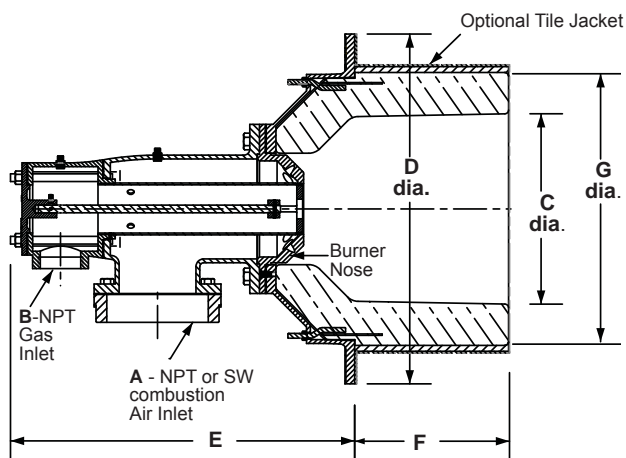

**Ordering Information**

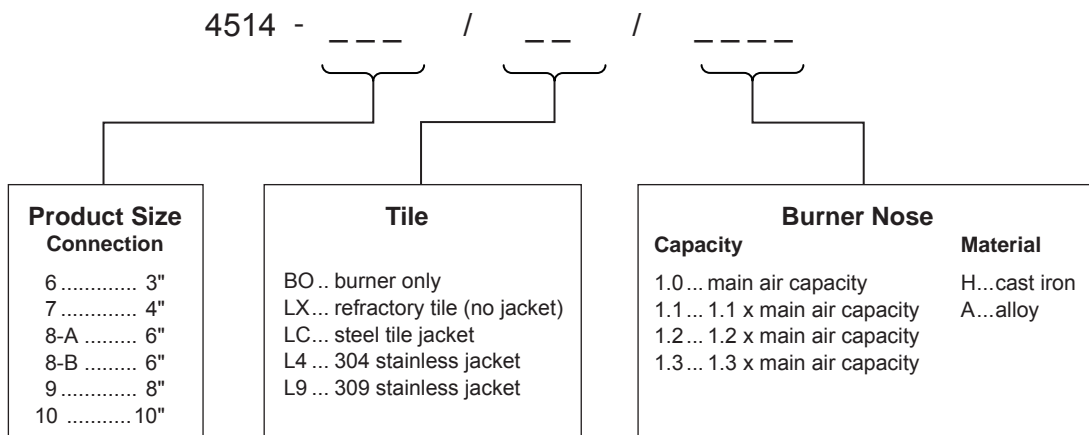

- Example 1 4514-8-A/LC/1.2A Fireall gas burner complete with carbon steel jacketed tile and 1.2 capacity alloy nose
  - Example 2 4514-6/BO/1.0H Fireall gas burner only with standard capacity iron nose
  - Example 3 4514-9/LX/1.2H Fireall gas burner complete with refractory tile and 1.2 capacity iron nose
- Note: See Supplement 6514-6 for cross referencing old product numbers.

**WARNING:** Situations dangerous to personnel and property may exist with the operation and maintenance of any combustion equipment. The presence of fuels, oxidants, hot and cold combustion products, hot surfaces, electrical power in control and ignition circuits, etc., are inherent with any combustion application. Parts of this product may exceed 160F in operation and present a contact hazard. Fives North American Combustion, Inc. urges compliance with National Safety Standards and insurance Underwriters recommendations, and care in operation.