

**7216 Variable Ratio Regulators** are used with nozzle-mix burners to achieve temperature uniformity while using minimum excess air. Molded diaphragms ensure excellent tracking and repeatability, maximum flows, and superior turndown. A high quality stainless steel spring is used to bias 7216 Regulator air/gas ratio. As air rate is turned down towards low fire, gas rate drops faster, giving increasing percentages of excess air (see Figure 2). Reduced total air means greater fuel economy.

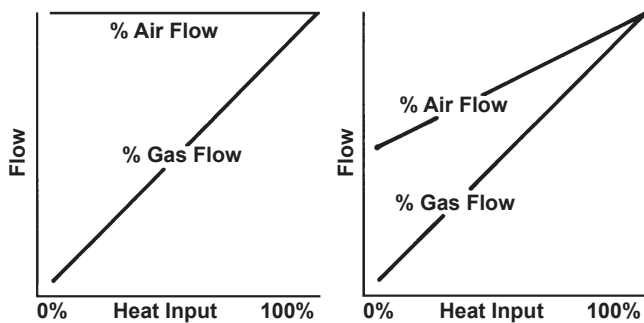

**Figure 1. Constant air throttled fuel control.**

**Figure 2. 7216 Regulator control.**

**Adjustment.** Regulators are set at zero bias as shipped. To set regulator bias, loosen locknut at base of spring cartridge, turn spring cartridge counterclockwise (do not remove cap), and retighten locknut. Set as negative as necessary to get temperature uniformity at low fire.

Where available gas pressure at the 7216 inlet is less than 2 psi above maximum combustion air pressure, use a bleeder in the air impulse line. See Bulletin 8654 or Instructions 7218-2.

If 1:1 ratio control is required at all firing rates, a 7218 Ratio Regulator is recommended, rather than a 7216. In some multi-purpose furnaces, 7216 and 7218 Regulators are piped in parallel with an isolation shutoff valve ahead of each. This permits holding constant ratio from high fire to low using the 7218, or variable ratio operation with the 7216.

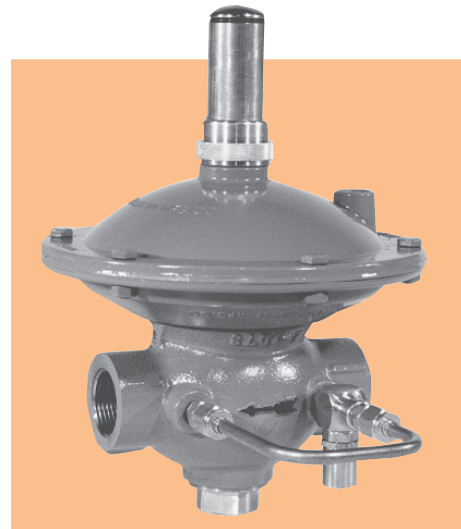

**7216-BP By-Pass Option (shown in picture above)**

The By-Pass Option provides a fixed low fire setting. Make sure any spring adjustments are done after the low fire flow rate has been set by adjusting the by-pass needle valve. This is to ensure that the spring force will counteract the weight of the parts as well as the low fire outlet pressure. If this is not done, the regulator will not track properly.

A By-Pass Kit is also offered for adding this option to a regulator already in the field. Order the appropriate kit by the following part number:

2-7168-1 By-Pass Kit for	7216-01, -0, -1
2-7168-3	7216-2
2-7168-4	7216-3
2-7168-5	7216-4
2-7168-6	7216-5
2-7168-7	7216-6
2-7168-8	7216-7

**SPECIFICATIONS**

- Diaphragm Cover and Case:** Aluminum
- Body:** Cast Iron
- Seat:** Brass
- Shaft:** SST
- Balancing Diaphragm:** BUNA/Nylon (Standard)  
FKM/Polyester (7216-V)
- Gas Diaphragm:** BUNA/Nylon (Standard)  
FKM/Nomex (7216-V)
- Maximum Inlet Pressure:** 2 psi

- Maximum Shock Load:** 5 psi
- Maximum Ambient Temperature:** 180° F (Standard)  
350° F (7216-V)
- Low Fire Accuracy at <3"wc impulse:**  
Spring bias setting capabilities: +0.2"wc to -7"wc  
Repeatability: ±0.05"wc
- High Fire Accuracy at 3" to 41.5"wc impulse:**  
Impulse/outlet pressure offset: 0.5 to 5% plus bias on regulator  
repeatability: ±0.3"wc

**WARNING:** Situations dangerous to personnel and property may exist with the operation and maintenance of a combustion equipment. The presence of fuels, oxidants, hot and cold combustion products, hot surfaces, electrical power in control and ignition circuits, etc. are inherent with any combustion application. Parts of this product may exceed 160F in operation and present a contact hazard. Fives North American urges compliance with National Safety Standards and insurance Underwriters recommendations, and care in operation.

## 7216 AIR/GAS RATIO REGULATORS

**Table 1. CAPACITIES**  
cfh  
**MAXIMUM WIDE OPEN**  
with 2 osi drop through regulator

Regulator designation	gas gravity			
	0.4	0.6	1.5	2
7216-01	348	285	180	156
7216-0	659	540	341	295
7216-1	854	700	442	383
7216-2	2110	1730	1090	946
7216-3	3420	2800	1770	1530
7216-4	5860	4800	3030	2630
7216-5	8420	6900	4360	3770
7216-6	11100	9100	5750	4980
7216-7	21470	17600	11120	9630

**Table 2. FACTORS**  
for capacities at other pressure drops

Pressure drop, osi	Factor	Pressure drop, osi	Factor
1	0.707	8	2.00
2	1.00	10	2.24
2 1/2	1.12	12	2.45
3	1.22	14	2.65
4	1.41	16	2.83

### REGULATOR SELECTION

To size a regulator, determine required cfh of gas and pressure drop available at high fire. Divide required cfh by Table 2 factor for available pressure drop. Select smallest regulator with Table 1 (2 osi) capacity above this adjusted capacity. **Never choose a regulator capacity based on more than 16 osi drop (even if more is available).**

### DIMENSIONS

Install with diaphragms horizontal and above the pipe.

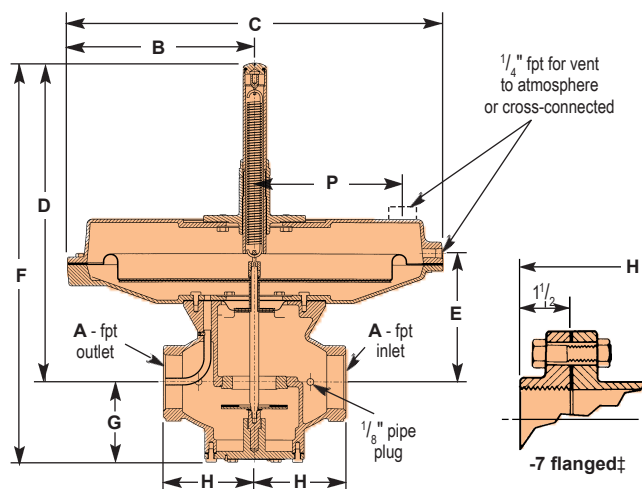

### RECOMMENDED INSTALLATION

Install with diaphragm horizontal and above the pipe.

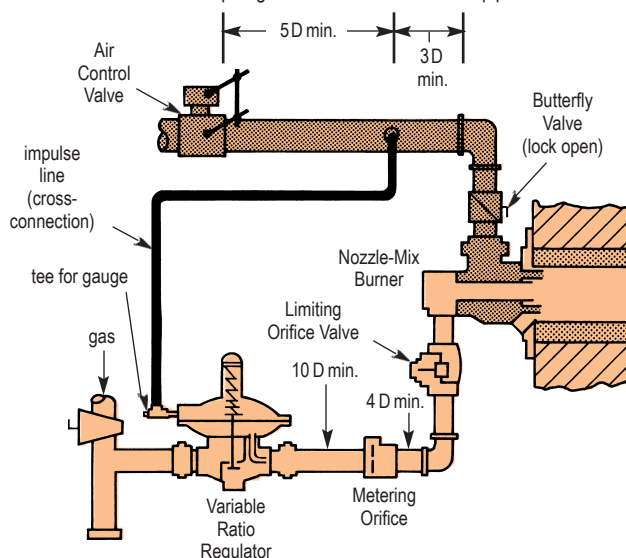

### ORDERING INSTRUCTIONS

**7216** - - -  
Product No.      Pipe Code

- "Blank" Standard
- V** = Viton (FKM) diaphragms and O-rings
- BP** = by-pass
- VBP** = bypass option with Viton (FKM) diaphragms
- RK** = repair kit
- VRK** = repair kit (V series)
- UK** = Upgrade kit for -5, -6, -7
- VUK** = Viton (FKM) upgrade kit for -5, -6, -7

Regulator designation	dimensions in inches									wt, lb
	A	B	C	D	E	F	G	H	P	
7216-01	1/2	3 3/4	7 1/2	8 11/32	-	10 7/32	2 1/4	2 1/2	2 11/16	7.5
7216-0	3/4	3 3/4	7 1/2	8 11/32	-	10 7/32	2 1/4	2 1/2	2 11/16	7.5
7216-1	1	3 3/4	7 1/2	8 11/32	-	10 13/32	2 7/16	2 3/4	2 11/16	8
7216-2	1 1/4	5 1/4	10 1/2	9 31/32	-	12 15/32	3	2 3/4	3 5/16	11.5
7216-3	1 1/2	5 1/4	10 1/2	9 31/32	-	12 19/32	3 1/8	3 1/4	3 5/16	12
7216-4	2	6 3/4	13 1/2	12 5/8	-	15 7/8	3 3/8	3 5/16	5 1/4	19.5
7216-5	2 1/2	9 1/4	18 1/2	19 1/2	6 7/16	23 13/32	4	4 1/2	-	37
7216-6	3	9 1/4	18 1/2	19 1/2	6 7/16	23 29/32	4 1/2	4 13/16	-	41
7216-7†	4	9 1/4	18 1/2	19 17/32	7 1/8	25 21/32	5 3/4	8 21/32	-	85

† Threaded companion flanges included in regulator price.

DIMENSIONS SHOWN ARE SUBJECT TO CHANGE. PLEASE OBTAIN CERTIFIED PRINTS FROM FIVES NORTH AMERICAN COMBUSTION, INC. IF SPACE LIMITATIONS OR OTHER CONSIDERATIONS MAKE EXACT DIMENSION(S) CRITICAL.

Fives North American Combustion, Inc., 4455 East 71st Street, Cleveland, OH 44105 USA, Phone 216.271.6000  
Fax 216.641.7852 email: fna.sales@fivesgroup.com • www.fivesgroup.com/fivesna