

**7218 REGULATORS** accurately maintain a constant air/gas ratio over a wide range of firing rates in both nozzle-mix and premix gas burner systems. Molded diaphragms ensure excellent tracking, repeatability, maximum flows, and superior turndown.



**7218 Regulators have soft seat for low flow control.**

**Table 1.** CAPACITIES  
 scfh  
**MAXIMUM WIDE OPEN**  
 with 2 osi drop through regulator  
 and 2 psig inlet pressure

Regulator designation	gas gravity	
	0.6	1.5
<b>7218-01</b>	285	180
<b>7218-0</b>	540	341
<b>7218-1</b>	700	442
<b>7218-2</b>	1730	1090
<b>7218-3</b>	2800	1770
<b>7218-4</b>	4800	3030
<b>7218-5</b>	6900	4360
<b>7218-6</b>	9100	5750
<b>7218-7</b>	17600	11120

(For capacities at other drops, use square root law or Table 2 on back of this sheet.)

### NOZZLE-MIX BURNERS

When used with nozzle-mix burners, the vent of a 7218 Regulator is cross-connected to the main air line downstream of the control valve. Regulator outlet pressure then equals air impulse pressure, and gas flow remains proportional to air flow at all firing rates.

One regulator can be used for several burners controlled by the same air valve, but often it is better to have a separate regulator for each burner.

**Dual-Fuel Burners.** When a dual-fuel burner's atomizing air is left on during gas operation, the 7218 Regulator can be set to compensate for the extra air over the controlled main air by adjusting the spring for up to 1 osi "leak" with no impulse pressure.

### PREMIX BURNERS

With its vent open to atmosphere, a 7218 Regulator can be used as an atmospheric regulator (zero governor) to supply gas to an aspirator mixer feeding premix burners.

If burner nozzles are sealed-in and furnace pressure is other than atmospheric, regulator vent must be connected to the combustion chamber. Controlled gas pressure then will match furnace pressure; this is necessary to maintain the same air/gas ratio at all firing rates. (See Instructions 7218-2.)

A separate regulator for each mixer is preferred to avoid interference or interaction.

## SPECIFICATIONS

**Diaphragm Cover and Case:** Aluminum

**Body:** Cast Iron

**Seat:** Brass

**Shaft:** SST

**Balancing Diaphragm:** BUNA/Nylon (Standard)  
 FKM/Polyester (7218-V)

**Gas Diaphragm:** BUNA/Nylon (Standard)  
 FKM/Nomex (7218-V)

**Maximum Inlet Pressure:** 2 psi

**Maximum Inlet Pressure:** 2 psi

**Maximum Shock Load:** 5 psi

**Maximum Ambient Temperature:** 180° F (Standard)  
 350° F (7218-V)

**Low Fire Accuracy at <3"wc impulse:**

Spring bias setting capabilities: -0.2"wc to +1.7"wc  
 Repeatability: ±0.05"wc

**High Fire Accuracy at 3" to 41.5"wc impulse:**

Impulse/outlet pressure offset: 0.5 to 5%  
 Repeatability: ±0.3"wc

**Turndown:** Exceeds 20:1

## 7218 AIR/GAS RATIO REGULATORS

**Table 2. FACTORS**  
for 7218 capacities at various pressure drops

Pressure drop, osi	Factor	Pressure drop, osi	Factor
1	0.707	8	2.00
2	1.00	10	2.24
2½	1.12	12	2.45
3	1.22	14	2.65
4	1.41	16	2.83
6	1.73		

### REGULATOR SELECTION

To size a regulator, determine required cfh of gas and pressure drop available at high fire. Divide required cfh by Table 2 Factor for available pressure drop. Select smallest regulator with Table 1 (2 osi) capacity above this adjusted capacity. **Never choose a regulator capacity based on more than 16 osi drop (even if more is available).**

#### EXAMPLES

A nozzle-mix system requires 5000 cfh of natural gas. Gas inlet pressure is 12 osi; maximum air pressure at the burner is 8 osi.

When cross-connected, outlet gas pressure is 8 osi at high fire; pressure drop across regulator is 12 – 8 = 4 osi. Table 2 factor for 4 osi is 1.41; 5000 cfh ÷ 1.41 = 3546 cfh. In the 0.6 sp gr column of Table 1, select a 7218-4 Regulator (rated at 4800 cfh.)

If air pressure at the burner was 16 osi but available gas pressure was still only 12 osi, a bleeder would be required in the cross connection. For minimum bleed†, select regulator for required cfh directly from Table 1 (2 osi) capacities; then bleed cross-connected air impulse at high fire from 16 osi to 10 osi (12 osi available gas pressure minus 2 osi drop through regulator). For the required 5000 cfh in this example, select a 7218-5 from Table 1.

If system was premix instead of nozzle-mix, regulator outlet pressure is zero, and pressure drop through the regulator would equal inlet gas pressure (12 osi). Table 2 factor is 2.45; 5000 ÷ 2.45 = 2040 cfh. Select a 7218-3 Regulator from Table 1.

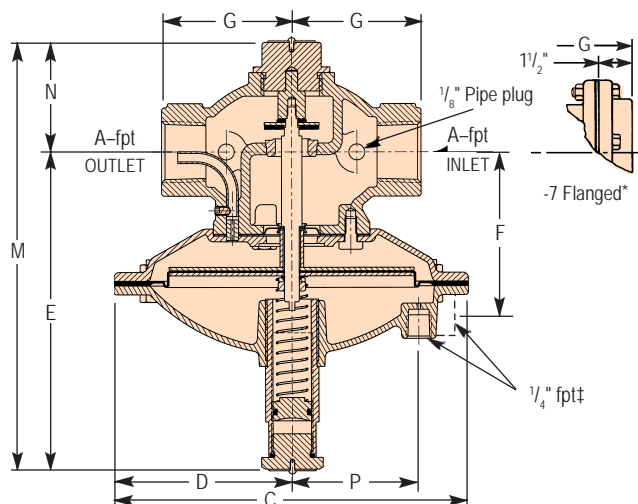

Install 7218 Regulators with diaphragm horizontal and below the pipe.

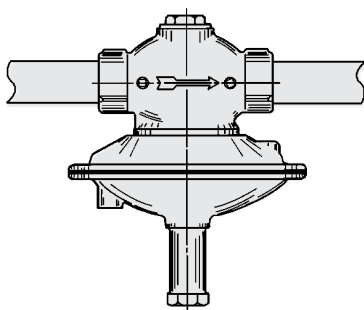

### ORDERING INSTRUCTIONS

**7218** - - -

Product Number └─ "Blank" Standard

Pipe Code └─ V = Viton (FKM) diaphragms and O-rings§

RK = repair kit  
 VRK = Viton (FKM) repair kit  
 UK = upgrade kit for -5,-6,-7  
 VUK = Viton (FKM) upgrade kit for -5, -6

Regulator designation	dimensions in inches									wt, lb
	A	C	D	E	F	G	M	N	P	
<b>7218-01</b>	½	7½	3¾	6⅞	—	2½	9⅛	2¼	2⅞	7.5
<b>7218-0</b>	¾	7½	3¾	6⅞	—	2½	9⅛	2¼	2⅞	7.5
<b>7218-1</b>	1	7½	3¾	6⅞	—	2¾	9⅝	2⅞	2⅞	8
<b>7218-2</b>	¼	10½	5¼	5 <sup>29</sup> / <sub>32</sub>	—	2¾	8 <sup>29</sup> / <sub>32</sub>	3	3 <sup>15</sup> / <sub>16</sub>	12
<b>7218-3</b>	½	10½	5¼	5 <sup>29</sup> / <sub>32</sub>	—	3⅛	9⅞	3⅞	3 <sup>15</sup> / <sub>16</sub>	13
<b>7218-4</b>	2	13½	6¾	7 <sup>3</sup> / <sub>16</sub>	—	3 <sup>3</sup> / <sub>16</sub>	10 <sup>9</sup> / <sub>16</sub>	3 <sup>3</sup> / <sub>8</sub>	5¼	17
<b>7218-5</b>	2½	18½	9¼	11 <sup>25</sup> / <sub>32</sub>	6 <sup>7</sup> / <sub>16</sub>	4½	15 <sup>25</sup> / <sub>32</sub>	4	—	38
<b>7218-6</b>	3	18½	9¼	11 <sup>25</sup> / <sub>32</sub>	6 <sup>7</sup> / <sub>16</sub>	4 <sup>13</sup> / <sub>16</sub>	16 <sup>9</sup> / <sub>32</sub>	4½	—	40
<b>7218-7*</b>	4	18½	9¼	12 <sup>9</sup> / <sub>32</sub>	7⅞	8 <sup>21</sup> / <sub>32</sub>	18 <sup>1</sup> / <sub>32</sub>	5¾	—	84

\* Threaded companion flanges included.  
 † Minimum bleed is desirable to realize highest possible impulse pressure for widest possible turndown.  
 ‡ For proper size impulse pipe, see paragraph A6 on Instructions 7218.  
 § 7218-7-V size not available. See 7216-7-V for high temperature applications.

DIMENSIONS SHOWN ARE SUBJECT TO CHANGE. PLEASE OBTAIN CERTIFIED PRINTS FROM FIVES NORTH AMERICAN COMBUSTION, INC.  
 IF SPACE LIMITATIONS OR OTHER CONSIDERATIONS MAKE EXACT DIMENSION(S) CRITICAL.

**WARNING:** Situations dangerous to personnel and property may exist with the operation and maintenance of a combustion equipment. The presence of fuels, oxidants, hot and cold combustion products, hot surfaces, electrical power in control and ignition circuits, etc., are inherent with any combustion application. Parts of this product may exceed 160F in operation and present a contact hazard. Fives North American urges compliance with National Safety Standards and insurance Underwriters recommendations, and care in operation.

Fives North American Combustion, Inc., 4455 East 71st Street, Cleveland, OH 44105 USA, Phone 216.271.6000  
 Fax 216.641.7852 email: fna.sales@f vesgroup.com • www.f vesgroup.com/f vesna