

7337 and 7347 Regulators reduce high gas supply pressures to practical use levels. 7337-3 and 7347 are Single-Port Regulators having internal relief valves, while the 7337A/B/C-4 and 7337-4 Regulators require a 7377 External Relief Valve to prevent downstream pressure build-up.

Since capacities will vary with the pressure drop across the regulator (see Tables B and D), due care must be exercised in properly sizing both the regulator and downstream piping. For 7347 Regulators, downstream piping may be enlarged only one pipe size from the regulator pipe size to increase capacity. Downstream piping for 7337 Regulators can be enlarged more than one size--see Table B. Outlet pressure of regulators (except where noted) may be varied through use of interchangeable compression springs within the groups indicated in selection Table C. Compression springs are identified by either color or part number.

CONSTRUCTION

Regulator valve bodies are made of cast iron; diaphragm casings of steel or aluminum, and diaphragm heads of steel. Diaphragms are of Buna-N with fabric insert; valve discs and "O" rings are synthetic rubber. Trim items generally are brass or aluminum, but in some models can be obtained in stainless steel on special order at extra cost--consult the home office.

SELECTION

When selecting a regulator, specify its complete designation including pipe size code and spring designation or outlet pressure range.

Example: Select a regulator for 4500 scfh of 1.5 sp gr propane gas from 20 psi supply pressure to 15 osi outlet pressure.

Solution: Convert the propane gas volume to the equivalent natural gas volume by using the factor from Table A: 4500 scfh of propane gas ÷ 0.632 = 7120 of natural gas. By interpolating, Table B indicates that proper downstream piping should be 3" for this flow and pressure. Entering Table D at the smallest regulator with this capacity yields a 7337-3. Referring to Table C for the required outlet pressure reveals that a 7337-3-LGN Regulator having an 8-17 osi spring should be used.

Table A. Specific Gravity Correction

Sp Gr	Factor
0.4	1.22
0.6	1.00
1.0	0.774
1.5	0.632
2.0	0.547

Divide desired flow by gravity factor to get equivalent flow of natural gas; then select regulator from Table C.

Multiply a given size regulator's natural gas capacity by gravity factor to get regulator capacity with different gas.

RELIEF VALVES

An External Type Relief Valve must be ordered with each 7337A/B/C-4 and 7337-4 Regulator. The relief valve is mounted between the regulator and a downstream shutoff valve to prevent pressure build-up and possible damage to other downstream equipment when the shutoff valve is opened. On 7337-3 and



7337-4 Regulator

7347 Regulators, internal pressure relief valves (connected to the vent) permit relief whenever downstream pressure exceeds the regulator setting (depending on the spring used). Shutoff valves located upstream of a high pressure regulator should be opened slowly to give the regulator time to respond. Relief valves and regulators should be vented to the outdoors. See Table C on page 2 for relief valve sizes.

Table B. Downstream Pipe Size for Good Control Capacities in scfh with 0.6 sp gr Natural Gas

Pipe Size inches	Effective outlet pressure in osi†		
	4	8	16
1¼	855	1210	1710
1½	1210	1710	2420
2	2190	3100	4380
2½	3400	4900	6800
3	5480	7750	11000
4	9800	13900	19600
6	23500	33300	47000
8	44500	63000	89000
10	69000	97000	138000

To interpolate in this table, use the square root law. Example: To find the capacity of a 3" pipe when effective outlet pressure is 10 osi, work from a nearby known figure, such as 7750 scfh at 8 osi:

$$\text{scfh at 10 osi} = 7750 \sqrt{10/8} = 8680 \text{ scfh.}$$

† Effective outlet pressure = Regulator outlet pressure minus combustion chamber pressure.

Table C. Outlet Pressures and Springs of High Pressure Regulators.

7337 Regulator Springs

Regulator Designation	Pipe size, inches	Outlet pressure range			Compression spring		Droop*	Companion Relief Valve
		"wc	osi	psi	Color	Number		
7347-0-G	¾	4-8	2-5	-	Red	R690-5278	1"wc	
7347-0-A	¾	15-33	9-19	-	Yellow	R690-5279	5.5"wc	
7347-0-B	¾	-	19-40	1.2-2.5	Lt Green	R690-5280	5.5"wc	
7347-1-G	1	4-8	2-5	-	Red	R690-5278	1"wc	
7347-1-A	1	15-33	9-19	-	Yellow	R690-5279	5.5"wc	
7347-1-B	1	-	19-40	1.2-2.5	Lt Green	R690-5280	5.5"wc	
7347-2-G	1¼	4-8	2-5	-	Red	R690-5278	1"wc	
7347-2-A	1¼	15-33	9-19	-	Yellow	R690-5279	5.5"wc	
7347-2-B [‡]	1¼	-	19-40	1.2-2.5	Lt Green	R690-5280	5.5"wc	
7337-3-GYS	1½	8.5-18	5-10	-	Gray	R690-5308	2"wc	
7337-3-GNS	1½	14-30	8-17	-	Green	R690-5375	3"wc	
7337-3-BS [‡]	1½	-	16-32	1-2	Blue	R690-5376	0.2"psi	
7337-3-LGY	1½	8.5-18	5-10	-	Gray	R690-5308	2"wc	
7337-3-LGN	1½	14-30	8-17	-	Green	R690-5375	3"wc	
7337-3-LB [‡]	1½	-	16-32	1-2	Blue	R690-5376	0.2 psi	
7337-4-G5	2	5-9	3-5	-	Black	R690-5377	1"wc	7377-1-2 ●
7337-4-G10	2	8.5-18	5-10	-	Gray	R690-5374	1"wc	7377-1-2 ●
7337-4-G16	2	14-28	8-16	-	Green	R690-5375	1"wc	7377-1-2 ●
7337-4-G32	2	-	12-32	0.75-2	Blue	R690-5376	10%	7377-1-2 ●
7337-4-G80	2	-	32-80	2-5	Yellow	R690-5378	10%	7377-1-5 □
7337-4-L1	2	-1 to +1	-	-	Silver	R690-5380	0.5"wc	7377-1-2 ●
7337-4-L2	2	0 to 4	-	-	Brown [§]	R690-5381	0.5"wc	7377-1-2 ●

7337A/B/C Regulator Springs

Regulator Designation	Pipe size, inches	Outlet Pressure Range			Spring Color	"R" Number	Companion Relief Valve
		"wc	osi	psi			
7337A/B/C-4-G4 [†]	2	3½-6½	2-3	-	Red	R690-5602	7377-1-2 ●
7337A/B/C-4-G8 [†]	2	6-14	3-8	-	Green	R690-5601	7377-1-2 ●
7337A/B/C-4-HG16 [†]	2	12-28	7-16	-	Orange	R690-5603	7377-1-2 ●
7337A/B/C-4-HG80 [†]	2	-	-	1-5	White	R690-5604	7377-1-5 □
7337A/B/C-4-L3 [†]	2	-	-	3-15	Gray	R690-5605	7377-1-5 or 7377-1-10 or 7377-1-25 □ ◇ ❖ ◆
7337A/B/C-4-L4 [†]	2	-	-	10-35	Brown	R690-5606	7377-1-10 or 7377-1-25 ◇ ❖ ◆

- ‡ Within a grouping, by exchanging interchangeable springs, the "B" regulator may be made into either of two regulators above it; and those two above may be changed into each other, but they cannot be changed into "B" regulators because they lack the high pressure diaphragm head assembly.
- The 7377-1-5 Relief Valve is factory set to start relieving at 5 psi. It can be field adjusted with a screwdriver from 4 to 15 psi but must not be set more than 3 psi above the setpoint of the 7337 Regulator. At capacities shown, droop will increase as set pressure is lowered from 5 psi.
- § The 7337-4-L2 Regulator has a silver extension spring installed inside a brown compression spring.
- The 7377-1-2 Relief Valve is factory set to start relieving at 2.5 psig. It can be field adjusted with a screwdriver from 1 to 4.5 psi, but must not be set more than 3 psi above the setpoint of the 7337 Regulator.
- ◇ The 7377-1-25 Relief Valve is factory set to start at 25 psig. It can be field adjusted with a screwdriver from 15 to 50 psi, but must not be set more than 3 psi above the setpoint of the 7337 Regulator.
- † Use a load limiting regulator for outlet pressures under 1 psig when inlet pressures exceed 40 psig.
- * Droop is the difference between outlet pressure selected and that realized when operating at capacities listed in this table.)
- ❖ Select correct relief setting per application. Relief setting must not be set more than 3 psi above the setpoint of the 7337 Regulator.
- ◆ The 7377-1-10 Relief Valve is factory set to start relieving at 10 psi. It can be field adjusted with a screwdriver from 4-15 psi, but must not be set more than 3 psi above the setpoint of the 7337 Regulator.

Table D. Capacities for High Pressure Regulators.

Regulator designation	Capacities in cfm of Natural Gas (0.6 sp gr) with Inlet Pressures in psi							Orifice dia. inches	Max. inlet pressure psi
	2	5	10	15	20	25	50		
7347-0-G	305	488	557	603	649	733	—	3/8	35
7347-0-A	600	1 118	1 420	1 673	1 925	2 178	—	3/8	35
7347-0-B	—	420	570	685	800	915	—	3/8	35
7347-1-G	503	1 136	1 974	1 572	1 169	1 089	—	3/8	35
7347-1-A	820	1 368	2 320	2 838	3 355	3 873	—	3/8	35
7347-1-B	—	448	710	943	1 175	1 408	—	3/8	35
7347-2-G	—	1 420	1 800	1 800	1 800	1 800	1 800	3/8	75
7347-2-A	300	1 500	2 000	2 790	3 580	4 390	5 160	3/8	60
7347-2-B	—	530	1 000	1 650	2 300	2 950	6 400	3/8	60
7337-3-GYS	1 200	2 000	2 800	3 500	4 100	4 700	7 500	3/8	60
7337-3-GNS	950	1 700	2 600	3 400	4 000	4 700	7 750	3/8	60
7337-3-BS	750	1 250	2 500	3 650	4 600	5 150	7 600	3/8	60
7337-3-LGY	2 700	3 900	5 500	6 500	7 750	7 750	7 750	3/4	60
7337-3-LGN	2 000	4 200	6 000	6 500	7 750	7 750	7 750	3/4	60
7337-3-LB	1 400	4 100	6 000	6 600	7 500	8 000	10 000	3/4	60
7337A-4-G4	2 250	3 900	6 000	7 700	9 000	10 300	16 800	1/2	150
7337B-4-G4	4 800	8 350	12 800	16 300	19 000	21 800	35 500	3/4	125
7337C-4-G4	7 800	13 700	21 000	26 700	31 200	35 700	58 200	1	60
7337B-4-G8	4 450	8 200	12 500	16 300	19 000	21 800	35 500	3/4	125
7337C-4-G8	7 300	13 500	20 400	26 700	31 200	35 700	58 200	1	60
7337A-4-HG16	2 000	3 750	5 800	6 800	9 000	10 300	16 800	1/2	150
7337B-4-HG16	4 450	7 850	12 350	14 500	19 000	21 800	35 500	3/4	125
7337C-4-HG16	7 300	12 900	20 200	23 600	31 200	35 700	58 200	1	60
7337A-4-HG80	—	2 600	4 650	6 800	8 800	10 300	16 800	1/2	150
7337B-4-HG80	—	5 500	9 850	14 500	18 700	21 800	35 500	3/4	125
7337C-4-HG80	—	9 100	16 200	23 600	30 500	35 700	58 200	1	60
7337A-4-L3	—	2 600	3 550	5 000	5 500	8 200	16 800	1/2	150
7337B-4-L3	—	5 550	7 550	10 700	11 700	17 200	35 500	3/4	125
7337C-4-L3	—	9 100	12 400	17 500	19 100	28 200	58 200	1	60
7337A-4-L4	—	—	—	5 000	5 500	5 900	15 400	1/2	150
7337B-4-L4	—	—	—	10 700	11 700	12 400	32 500	3/4	125
7337C-4-L4	—	—	—	17 500	19 100	20 200	53 200	1	60
7337-4-G5	17 000	32 000	48 000	63 000	79 000	90 000	145 000	—	60
7337-4-G10	8 200	16 000	34 000	51 000	69 000	80 000	130 000	—	60
7337-4-G16	—	14 000	26 000	43 000	60 000	73 000	132 000	—	60
7337-4-G32	—	20 500	38 000	50 000	62 000	74 000	124 000	—	60
7337-4-G80	—	—	24 000	35 000	46 000	55 000	103 000	—	60
7337-4-L1	11 500	22 000	44 000	50 000	76 000	—	—	—	20

○ Maximum practical capacity.

Note: 7337-4 Regulators: If the maximum flow is greater than 87,000 scfh, contact Fives North American for proper relief valve.

DIMENSIONS

inches

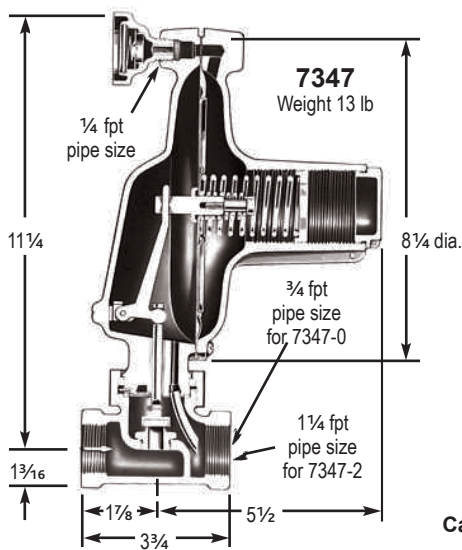
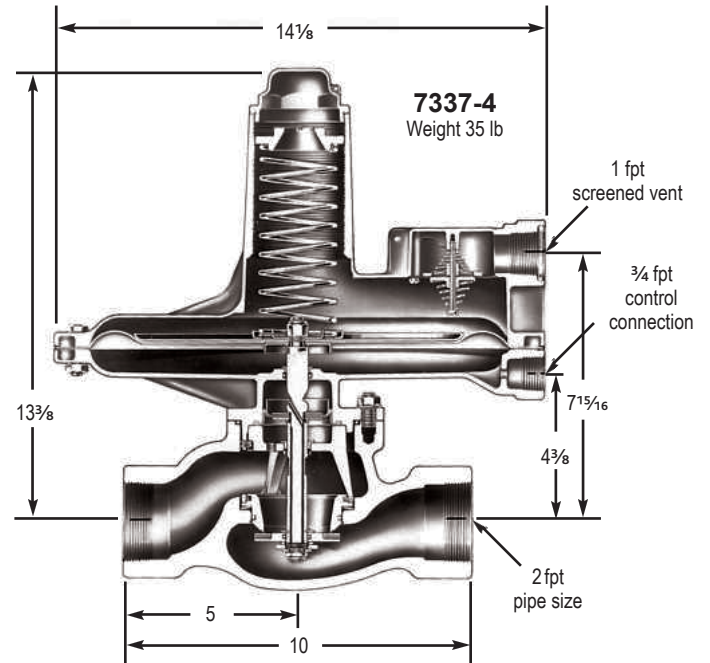
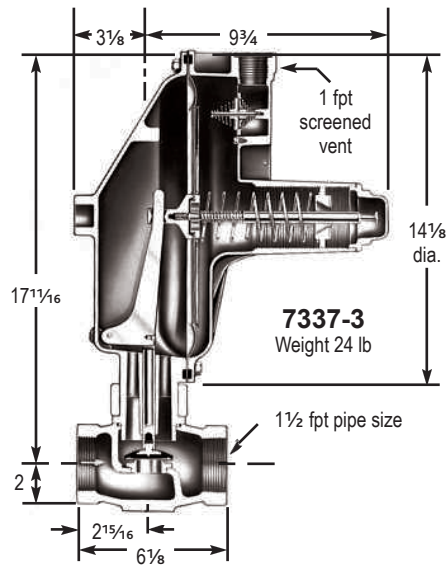

7377-1
Weight 4 lb

Temperature
Capability
-20 F to 150 F

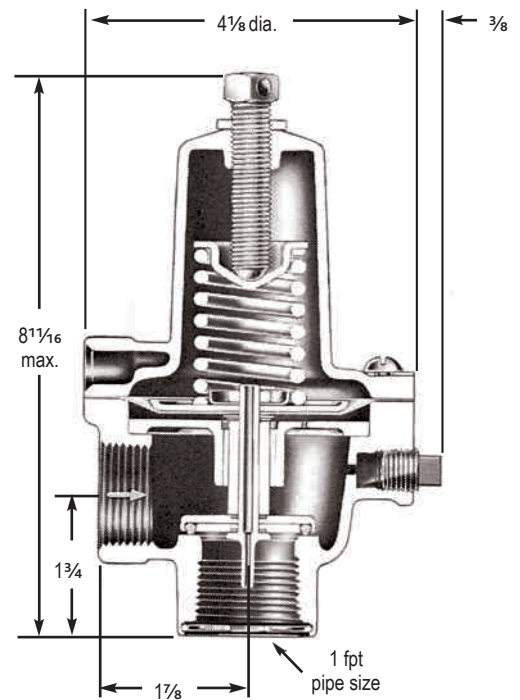

DIMENSIONS SHOWN ARE SUBJECT TO CHANGE. PLEASE OBTAIN CERTIFIED PRINTS FROM FIVES NORTH AMERICAN COMBUSTION, INC. IF SPACE LIMITATIONS OR OTHER CONSIDERATIONS MAKE EXACT DIMENSION(S) CRITICAL.

DIMENSIONS

inches

7337A/B/C-4 Regulator

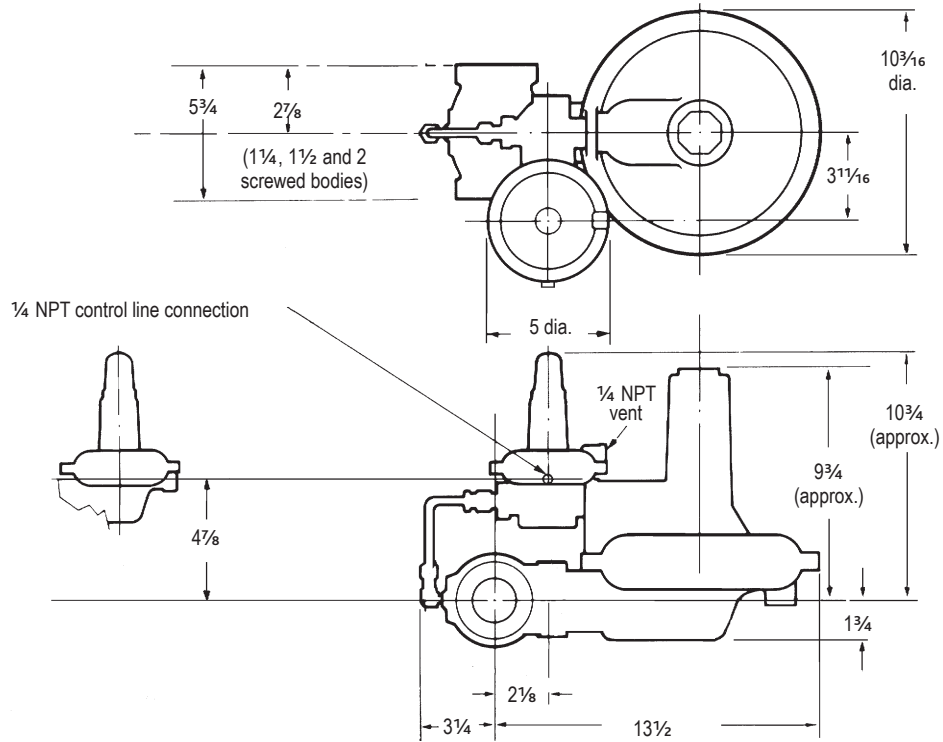

MOUNTING POSITIONS

Position No. 1

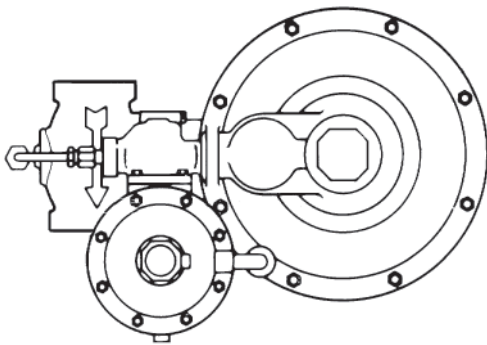

Position No. 2

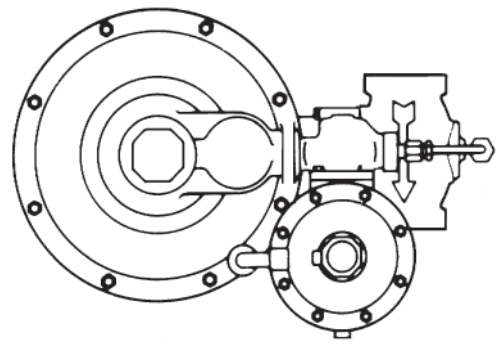

Note: If not specified, position No. 1 will be furnished.

