

Figure 1. 7349 Pressure-Reducing Gas Regulator.

**7349 Pressure-Reducing Gas Regulators** deliver constant outlet pressure regardless of changes in inlet pressure (not pulsations). Large clearance internal guides eliminate friction that might cause time lag, yet minimize chatter. A soft valve seat provides nearly tight shutoff. Two basic models are available: 7349 with an internal impulse tap, and 7349- -S with external impulse tap for maintaining pressures at remote downstream locations.

**Pressures and Temperatures.**

Inlet pressure--5 psig maximum.  
 Outlet pressure--available in 4 ranges, specify:

- "Y" Spring (yellow)..... for 1 to 4 osi range
- "A" Spring (aluminum) ..... for 3 to 8 osi range
- "G" Spring (green) ..... for 7 to 16 osi range
- "R" Spring (red) ..... for 14 to 24 osi range

The standard 7349 Regulator is suitable for 180 F maximum ambient temperature. For ambients up to 300 F with cool gas flowing, the 7349- -V Regulator is available with Viton-coated dacron diaphragms. For gases corrosive to brass, specify 7349- -K, incorporating stainless steel internals in place of brass and with Viton diaphragms. Gas capacities of 7349- -K and -V Regulators are same as corresponding standard versions.

**Installation.** Mount in horizontal lines with the adjustment spring either straight up or straight down (spring down mounting produces less outlet pressure because of the weight of internals). Figure 2 shows a 7349 Regulator with a cross-connected 7218 Regulator. To avoid interaction, allow a run of 15 or more pipe diameters between the regulators.

**Adjusting Instructions.** Pull off the cap and, with a wrench, turn the adjusting screw clockwise to increased outlet pressure (counterclockwise for less pressure). The spring, not the screw, moves up and down. To avoid exceeding the spring range, make adjustments only under flow conditions with a pressure gauge on the outlet tap of the regulator. Turning the screw down too tightly can prevent the regulator from closing. **Note:** When changing springs, turn adjusting screw counterclockwise to relax spring before removing 3 socket head cap screws.

**To order, specify:** 7349-(code for pipe size)-(modifiers K, S, V) (spring code letter).

Example: 7349-4-SVY (for a 2" regulator with external impulse tap, Viton diaphragms, and 1 to 4 osi outlet range).

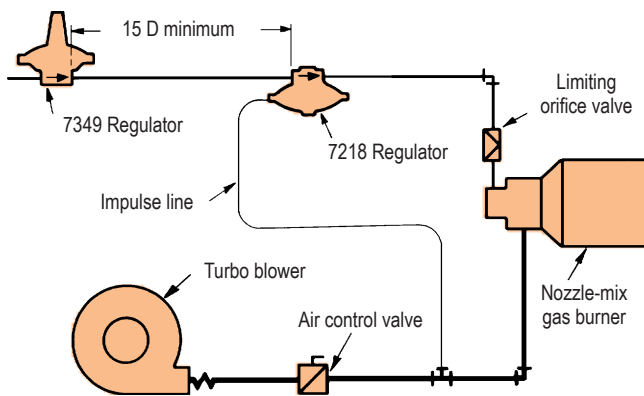

Figure 2. Pipe Arrangement for 7349 and 7218 Regulators.

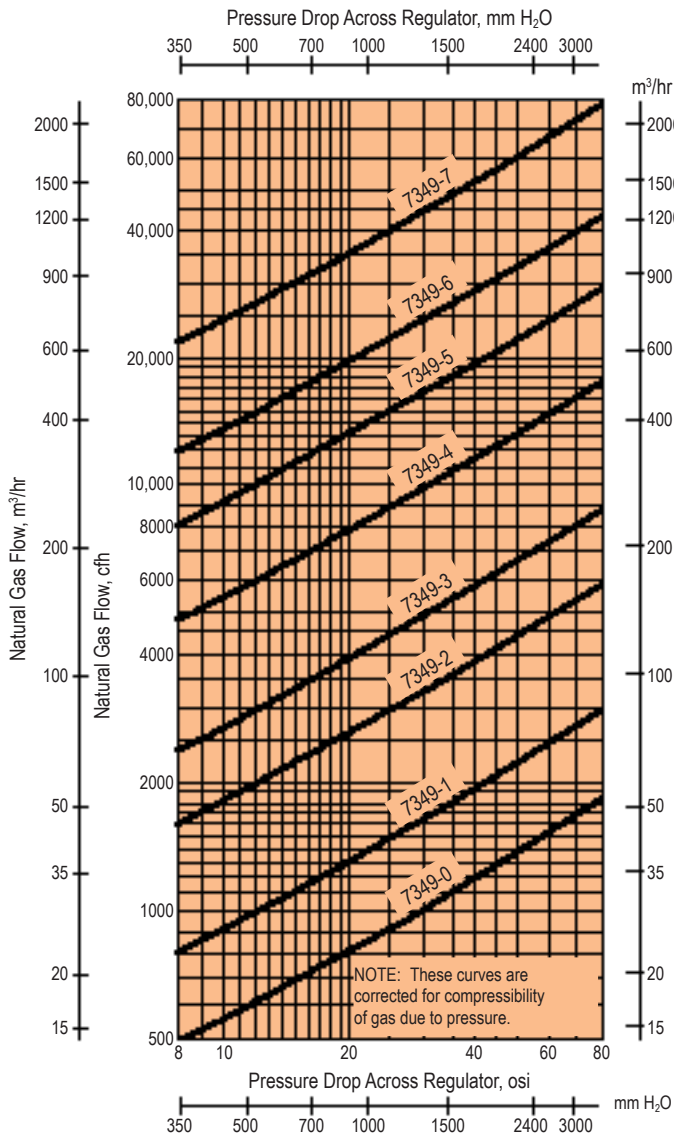

Figure 3. Capacities of 7349 and 7349-S Regulators.

**Selection.** On Figure 3, locate the intersection of lines corresponding to maximum required gas flow and pressure drop available across the regulator, move up to the diagonal line immediately above that point, and select the regulator whose designation appears on that line.

Capacities for 7349 and 7349-S models are identical, and both hold outlet pressures with approximately the same degree of accuracy. Use the 7349-S to maintain downstream gas pressure at a point remote from the regulator itself. **Never locate the remote tap downstream of another regulator or control valve, however.** See Figure 6 for installation of 7349-S Regulators.

Be sure pipe downstream of the regulator is adequately sized. Pipe of a larger size than the regulator connection is often necessary. To determine the pipe size needed, use Figure 4: Starting with the maximum cfm natural gas the pipe must handle, read across to the diagonal line corresponding to the pipe size of the regulator and read down to the pressure drop. This is the drop per 100 equivalent feet of pipe. For equivalent lengths of pipe fittings, see Table on Equivalent Lengths of Pipe Fittings in Part 5, **North American Combustion Handbook**, Third Edition, Vol. I. If the actual installation will have 50 equivalent feet downstream of the regulator, actual drop will be half the figure shown, and so on. If this drop is excessive, repeat the procedure for the next larger pipe size. See selection examples for more details.

When selecting a regulator for other than natural gas, divide required flow by the appropriate gas gravity factor (Table A) and use the resulting equivalent flow to size the regulator from Figure 3 and downstream pipe from Figure 4.

TABLE A. Regulator capacity correction factors for different gas gravities.

Gas (typical)	Coke oven	Natural	Air	Propane	Butane
Gas Gravity	0.4	0.6	1.0	1.5	2.0
Factor	1.22	1.00	0.774	0.632	0.547

Example 1. Select a regulator and size downstream piping for 60 000 cfm natural gas with 5 psi (80 osi) inlet and 15 osi outlet pressure. Maximum drop permitted in 20 equivalent feet of downstream pipe is 2 osi.

Pressure drop across the regulator is 80 – 15 = 65 osi. From Figure 3, select a 7349-7-G (or 7349-7-SG).

The permitted 2 osi drop in 20 ft is equivalent to 10 osi in 100 ft. From Figure 4, 100 equivalent feet of 4" pipe will pass 60 000 cfm natural gas with 14.5 osi drop, or 100 feet of 6" pipe will pass 60 000 cfm with 1.8 osi drop. Use 6" pipe and the pressure drop in 20 feet will be  $1.8 \times 20/100 = 0.36$  osi.

Example 2. Select a regulator for 1950 cfm 0.4 sg coke oven gas with 15 osi inlet pressure. Assume 2 osi furnace back-pressure, 3 osi drop across downstream valves and burners, and 1 osi maximum drop in 10 equivalent feet of downstream piping.

Regulator outlet pressure required is  $2 + 3 + 1 = 6$  osi, so regulator drop is  $15 - 6 = 9$  osi. Natural gas flow equivalent to 1950 cfm coke oven gas is  $1950 \div 1.22 = 1600$  cfm (from Table A). From Figure 3, a 7349-2-KA or 7349-2-SKA is required. From Figure 4, 1600 equivalent cfm of natural gas flowing through 10 feet of 1 1/4" pipe (same pipe size as regulator connections) will take a pressure drop of  $3.3 \div 10/100 = 0.33$  osi, which is well within the originally assumed 1 osi.

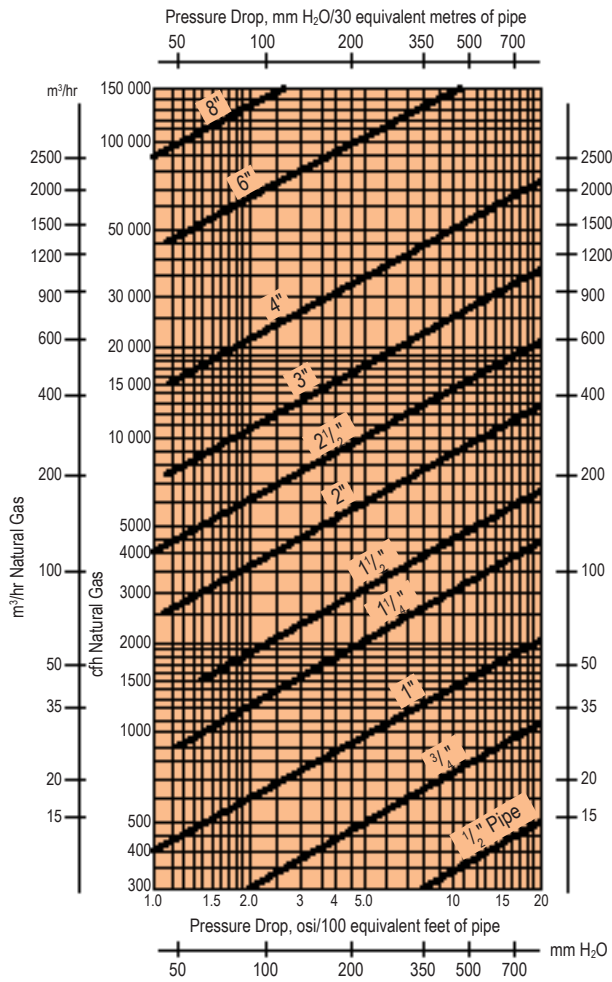
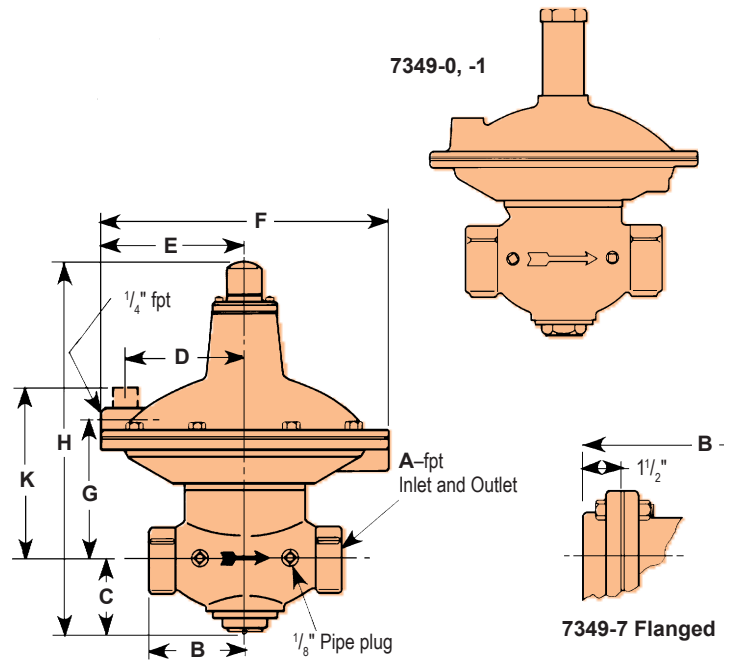

Figure 4. Pressure Drop in Downstream Pipe.



Regulator designation	dimensions in inches									wt, lb
	A	B	C	D	E	F	G	H	K	
7349-0	3/4	2 1/2	1 7/8	2 11/16	—	7 1/2	—	8 3/4	3 15/16	7
7349-1	1	2 3/4	2 1/16	2 11/16	—	7 1/2	—	8 15/16	3 15/16	8
7349-2	1 1/4	2 3/4	2 1/2	—	5 1/4	10 1/2	3 25/32	13	—	13
7349-3	1 1/2	3 1/16	2 5/8	—	5 1/4	10 1/2	3 25/32	13 1/8	—	14
7349-4	2	3 5/16	3 1/4	—	6 3/4	13 1/2	4 9/32	16	—	18
7349-5	2 1/2	4 1/2	4 3/8	—	9 1/4	18 1/2	6 11/32	21 9/16	—	40
7349-6	3	4 13/16	4 7/8	—	9 1/4	18 1/2	6 11/32	22 1/16	—	43
7349-7	4	8 2 1/2	5 3/4	—	9 1/4	18 1/2	6 27/32	23 1/2	—	87

Figure 5. Dimensions of 7349 Regulators.

Figure 6. Installation of 7349-S with External Impulse Tap

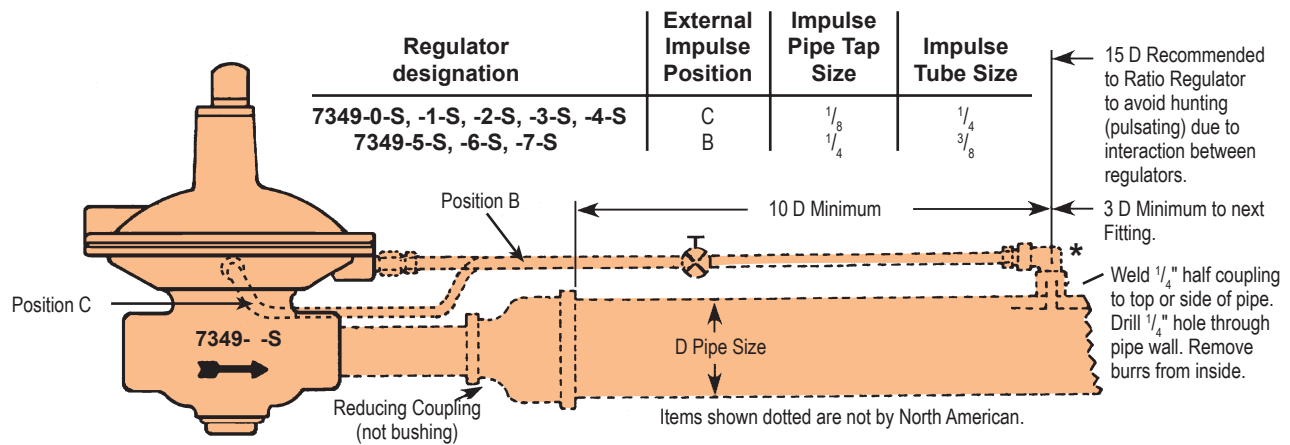

\*Never locate the remote tap downstream of another regulator or control valve.

DIMENSIONS SHOWN ARE SUBJECT TO CHANGE. PLEASE OBTAIN CERTIFIED PRINTS FROM FIVES NORTH AMERICAN COMBUSTION, INC. IF SPACE LIMITATIONS OR OTHER CONSIDERATIONS MAKE EXACT DIMENSION(S) CRITICAL.

**WARNING:** Situations dangerous to personnel and property may exist with the operation and maintenance of an combustion equipment. The presence of fuels, oxidants, hot and cold combustion products, hot surfaces, electrical power in control and ignition circuits, etc., are inherent with any combustion application. Parts of this product may exceed 160F in operation and present a contact hazard. Fives North American urges compliance with National Safety Standards and insurance Underwriters recommendations, and care in operation.

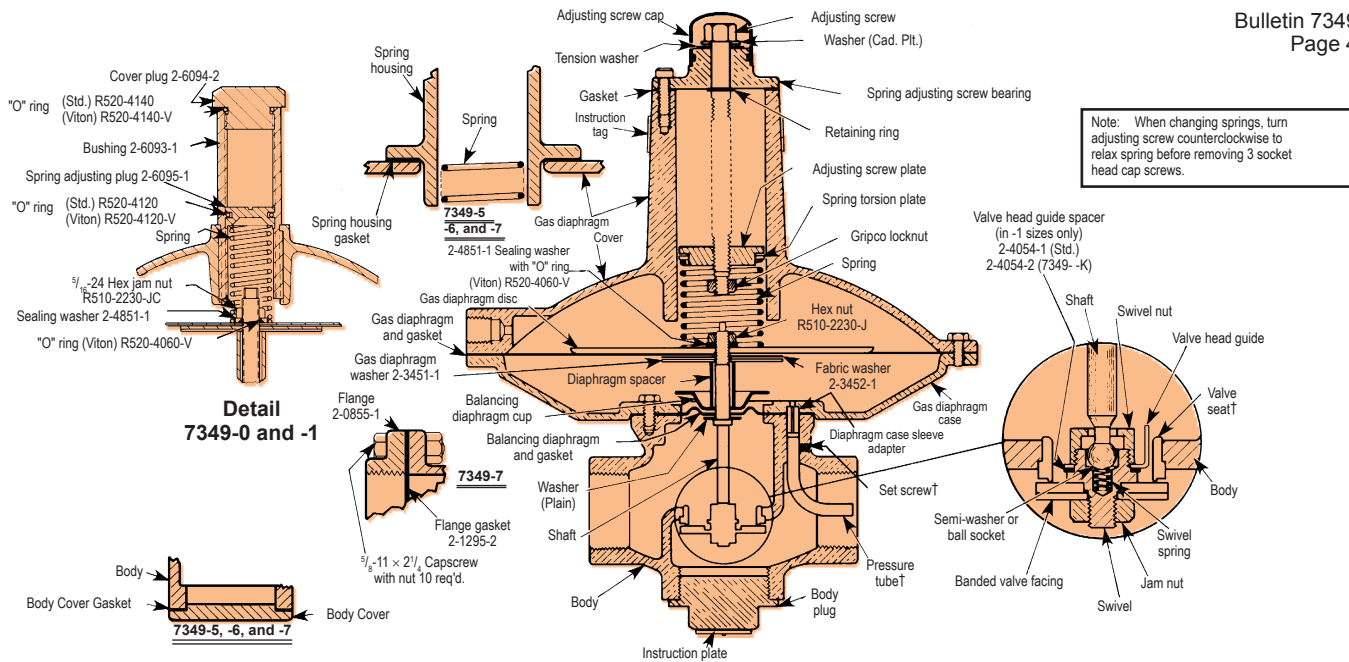

Note: When changing springs, turn adjusting screw counterclockwise to relax spring before removing 3 socket head cap screws.

Part name	Regulator designation							
	7349-0	7349-1	7349-2	7349-3	7349-4	7349-5	7349-6	7349-7
Adjusting Screw	See Detail for -0 and -1							
Adjusting Screw Cap	2-3923-1							
Adjusting Screw Plate	2-3904-1							
Balancing Diaphragm & Gasket Assem. (Std.) □	2-6246-1•	2-6246-1•	2-6247-1•	2-6247-1•	2-6248-1•	2-6405-1•	2-6405-1•	2-6406-1•
Balancing Diaphragm Cup	2-1290-1	2-1290-1	2-1290-2	2-1290-2	2-1290-3	2-1290-4	2-1290-4	2-2736-1
Balancing Diaphragm V (Viton) ①	2-4451-1	2-4451-1	2-4452-1	2-4452-1	2-4453-1	2-4454-1	2-4454-1	2-4455-1
Balancing Diaphragm Gasket (Viton) ①	2-5743-2§	2-5743-2§	2-5753-2§	2-5753-2§	2-6191-2§	2-6403-2§	2-6403-2§	2-6404-2§
Body (Std.) †	2-6253-1	2-6253-5	2-6253-9	2-6253-13	2-6253-17	2-6253-21	2-6253-25	2-6253-29
Body (7349-K) †	2-6253-2	2-6253-6	2-6253-10	2-6253-14	2-6253-18	2-6253-22	2-6253-26	2-6253-30
Body Cover Gasket	—							
Body Plug or Body Cover (Std.)	2-2036-1	2-2036-1	2-2038-1	2-2038-1	2-2043-1	2-3840-1	2-3840-1	2-2739-1
Body Plug (7349-K)	2-2036-2	2-2036-2	—	—	—	2-3839-1	2-3839-1	2-2738-1
Bonded Valve Facing	2-3941-2	2-3941-2	2-3942-2	2-3942-2	2-3943-2	2-3944-2	2-3944-2	2-3945-2
Diaphragm Spacer	2-1228-1	2-1228-1	2-1228-6	2-1228-6	2-1228-3	2-1228-4	2-1228-4	2-1228-4
Diaphragm Case Sleeve Adapter	2-6232-1	2-6232-1	2-6232-1	6-6232-1	—	—	—	—
Gas Diaphragm (Std.) □	—	—	—	—	—	2-4086-1	2-4086-1	2-4086-1
Gas Diaphragm V (Viton) ①	—	—	—	—	—	2-4086-2	2-4086-2	2-4086-2
Gas Diaphragm Case	2-5664-1	2-5664-2	2-5748-1	2-5748-2	2-6052-1	2-3800-2	2-2113-4	2-3939-2
Gas Diaphragm Cover	2-5670-1	2-5670-1	2-3906-1	2-3906-1	2-3907-1	2-3908-1	2-3908-1	2-3908-1
Gas Diaphragm Disc	2-4049-1	2-4049-1	2-4084-1	2-4084-1	2-4080-1	2-4059-1	2-4059-1	2-4059-1
Gas Diaphragm & Gasket Assem. (Std.)	2-6250-1•	2-6250-1•	2-6251-1•	2-6251-1•	2-6252-1•	—	—	—
Gas Diaphragm (Std.)	—	—	—	—	—	2-4086-1	2-4086-1	2-4086-1
Gas Diaphragm Gasket (Std.)	—	—	—	—	—	2-6407-1	2-6407-1	2-6407-1
Gas Diaphragm & Gasket Assem. V (Viton) ①	2-6250-2•	2-6250-2•	2-6251-2•	2-6251-2•	2-6252-2•	—	—	—
Gas Diaphragm (Viton) ①	—	—	—	—	—	2-4086-2	2-4086-2	2-4086-2
Gas Diaphragm Gasket (Viton) ①	—	—	—	—	—	2-6407-2	2-6407-2	2-6407-2
Gasket	—	—	2-3930-1	2-3930-1	2-3930-1	2-3901-1	2-3901-1	2-3901-1
Grippo Locknut	R510-5090-C	R510-5090-C	R510-5098-C	R510-5098-C	R510-5098-C	R510-5150	R510-5150	R510-5150
Instruction Plate	2-3838-1	2-3838-1	2-3838-1	2-3838-1	2-3838-1	2-2800-1	2-2800-1	2-2800-1
Instruction Tag (2 req'd.)	2-3892-1	2-3892-1	2-3892-1	2-3892-1	2-3892-1	2-3892-1	2-3892-1	2-3892-1
Jam Nut R510-5090-C	R510-5090-C	R510-5092-JC	R510-5092-JC	R510-5092-JC	R510-5099-JC	R510-5099-JC	R510-5099-JC	R510-5099-JC
"O" Ring V (Viton) ①	R520-4060-V	R520-4060-V	R520-4060-V	R520-4060-V	R520-4060-V	R520-4060-V	R520-4060-V	R520-4060-V
Retaining Ring	—	—	R740-7190	R740-7190	R740-7190	R740-6080	R740-6080	R740-6080
Semi-Washer or Ball Socket (Std.)	2-4067-1	2-4067-1	2-4067-1	2-4067-1	2-4067-1	2-4062-1§	2-4062-1§	2-4062-1§
Semi-Washer or Ball Socket (7349-K)	2-4067-2	2-4067-2	2-4067-2	2-4067-2	2-4067-2	2-4062-2	2-4062-2	2-4062-2
Shaft (Std.)	2-4083-3	2-4083-3	2-4083-1	2-4083-1	2-4083-2	2-4068-1	2-4068-1	2-4065-1
Shaft (7349-K)	2-4083-4	2-4083-4	2-4083-5	2-4083-5	2-4083-6	2-4068-2	2-4068-2	2-4065-2
Spring (4 osi Y—Yellow)	2-6097-1	2-6097-1	2-3917-1	2-3917-1	2-3919-1	2-3921-2	2-3921-2	2-3921-2
Spring (8 osi A—Aluminum)	2-6098-1	2-6098-1	2-3918-1	2-3918-1	2-3920-1	2-3922-2	2-3922-2	2-3922-2
Spring (16 osi G—Green)	2-6100-1	2-6100-1	2-4319-1	2-4319-1	2-4320-1	2-4321-1	2-4321-1	2-4321-1
Spring (24 osi R—Red)	2-6099-1	2-6099-1	2-4945-1	2-4945-1	2-4946-1	2-4947-1	2-4947-1	2-4947-1
Spring Adj. Screw Bearing	—	—	2-3925-1	2-3925-1	2-3925-1	2-3900-1	2-3900-1	2-3900-1
Spring Housing	—	—	—	—	—	2-3911-1	2-3911-1	2-3911-1
Spring Housing Gasket	—	—	—	—	—	2-3924-1	2-3924-1	2-3924-1
Spring Torsion Plate	—	—	2-3928-2	2-3928-2	2-3928-3	2-3903-2	2-3903-2	2-3903-2
Swivel	2-3313-6	2-3313-6	2-4116-1	2-4116-1	2-4116-1	2-4060-1	2-4060-1	2-4060-1
Swivel Nut	2-3385-2	2-3385-2	2-3385-2	2-3385-2	2-3385-2	2-4063-1	2-4063-1	2-4063-1
Swivel Spring	2-3314-1	2-3314-1	2-3314-1	2-3314-1	2-3314-1	—	—	—
Tension Washer	—	—	2-4359-2	2-4359-2	2-4359-2	2-4359-3	2-4359-3	2-4359-3
Valve Head Guide	—	2-4053-1	2-4079-1	2-4079-1	2-4085-1	2-4066-1	2-4066-1	2-4064-1
Washer (Cadmium Plated)	—	—	R970-7295-C	R970-7295-C	R970-7295-C	R970-7370-C	R970-7370-C	R970-7370-C
Washer	2-0541-1	2-0541-1	2-0541-1	2-0541-1	2-0541-1	2-2340-1	2-2340-1	2-2340-1

† Body includes Pressure Tube, Valve Seat, and Set Screw.  
 § Two required. □ Recommended Spare Parts.  
 ① All regulators containing Viton materials are not field repairable.

\* Is a Diaphragm and Gasket Assembly.

§ Gasket — Order with Diaphragm.