

Features:

- Normally-closed
- Electrically actuated
- Swinging gate body
- For shutoff service



TEMPERATURE LIMITS

All valves can handle **fluid temperatures** from -20 F (-28 C) to +250 F (+121 C).

**Ambient temperature limits vary.** Any valve on this page using dc voltage and all 1/2" and 3/4" series 1517 and 1517U Valves can handle ambient temperatures from -20 F (-28 C) to +125 F (+52 C). The other valves on this page handle ambient temperatures from -20 F (-28 C) to +140 F (+60 C).

OPERATION

All electro-mechanical valves require a constant supply of electrical energy to their holding actuator solenoids. Once the solenoid is energized, the manual reset valve may be opened manually, or the automatic reset valve will automatically open. Interruption of electrical power causes an immediate "trip" of the valve to its normally-closed position.

Body Material	Gray Iron		Cast Steel	
Top Assembly Function	Sanctioned Service ①	Special Service (Unlisted) <sup>②</sup>	Sanctioned Service ①	Special Service (Unlisted) <sup>②</sup>
Manual Reset	1516-1 1516-2	1516U-1 1516U-2	1516-1-S 1516-2-S	1516U-1-S 1516U-2-S
Automatic Reset	1517-01 1517-0 1517-1 1517-2	1517U-01 1517U-0 1517U-1 1517U-2	1517-01-S 1517-0-S 1517-1-S 1517-2-S	1517U-01-S 1517U-0-S 1517U-1-S 1517U-2-S

① **Sanctioned series** are sold for "clean fuel oils" and carry UL, FM, and CGA sanctions. They are IRI approvable for liquefied petroleum gases, #1 and #2 fuel oils, kerosene, JP-4 and preheated #4, #5, and #6 oils with maximum viscosity of 5000 SSU.

② **Non-sanctioned series** do not carry blanket approval/listings, and the pressure limits shown apply only for selected special service applications. An analysis of your fluid will determine the actual rating, trim, and specifics for your application.

Available Sizes and Pressure Ratings

Pipe Size inches	Body C <sub>v</sub> Flow Factor	Maximum Inlet Pressure, psig <sup>③</sup>			
		Gray Iron Bodies		Cast Steel Bodies	
		Clean Gases & Oils	Special Service	Clean Gases & Oils	Special Service
1/2	3.4	300	300	600	600
3/4	9.6	300	300	600	600
1	12	300	300	600	600
1 1/4	17	300	300	600	600

③ Maximum operating pressure differential must not exceed the maximum inlet pressure.

## CAPACITIES WITH No. 2 OIL

To select a valve for YOUR application, use either  $C_v$  factor calculations, or this graph showing approximate pressure drop at various flows of #2 oil.

Typically, pressure drop for fuel flows should not exceed 10% of inlet pressure.

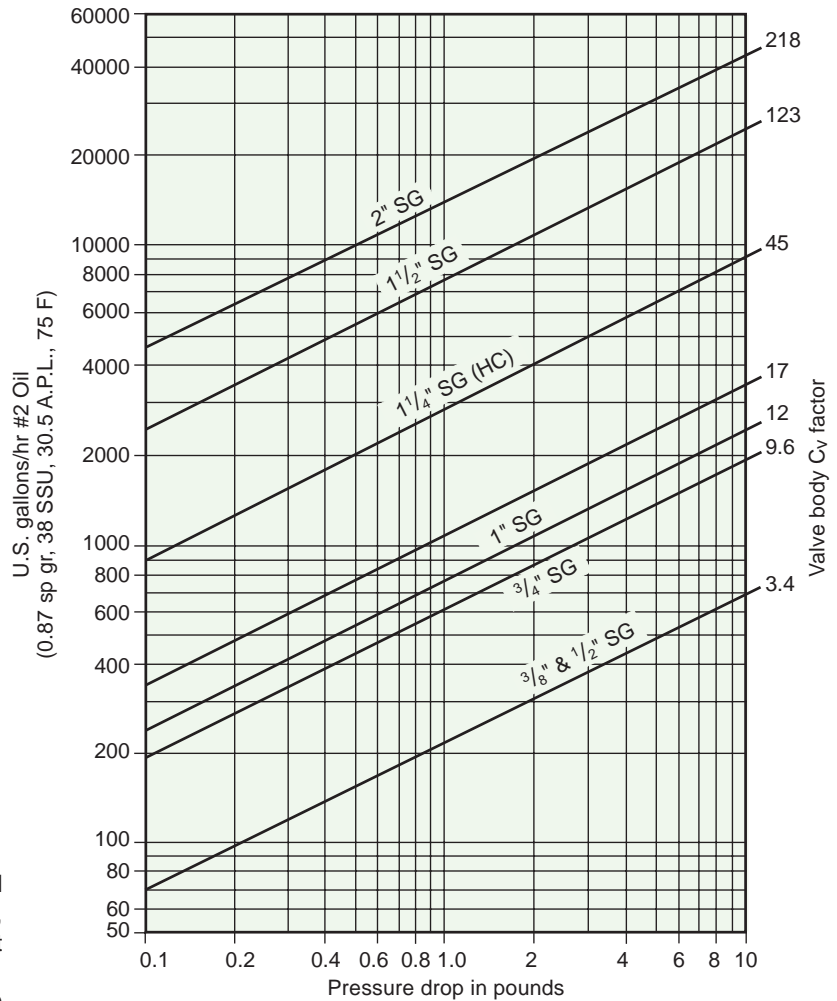

For preheated #5 or #6 oil, multiply the required flow rate in gph by the factor in the table at right, then select a valve based upon that equivalent flow of #2 oil and the allowable pressure drop.

For example: To size for 5 psig drop with a 3500 gph flow of #6 oil preheated to 140 F, the multiplier is 2. Equivalent flow of #2 oil is then  $3500 \times 2$ , or 7000 gph. Chart shows that a 5 psig drop requires a valve body with a  $C_v$  factor of at least 45.

Oil Grade	#5		#6				
°F at Inlet	125	160	120	140	180	210	220
Factor	1.43	1.11	2.86	2.00	1.25	1.11	1.05

## VALVE SELECTION CHART

1516/1517 Oil Shutoff Valves		
Material Specifications	Sanctions	Available in Series
1-B valve sizes 1" and 1 1/4"	UL, FM, CGA	1516-1, -2 1517-1, -2
	Non-sanctioned	1516U-1, -2 1517U-1, -2
1-D valve sizes 1/2" and 3/4"	UL, FM, CGA	1517-01, -0
	Non-sanctioned	1517U-01, -0
2-D all valve sizes	UL, FM, CGA	1516-1, -2-S 1517-1, -2-S 1517-01, -0-S
	Non-sanctioned	1516U-1, -2-S 1517U-1, -2-S 1517U-01, -0-S

## ELECTRICAL DATA for normally-closed valves

### General

Shutoff valves are electrically actuated from the flame safe-guard and/or safety control circuits.

Standard valve assemblies include an internal holding solenoid or printed circuit board for 120 volt 60 hertz ac power. (Other electrical current options are available upon request.)

1516/1517 Valves have the internal solenoid. The solenoid (or the printed circuit board) is energized whenever the valve is powered. The motor operator on automatic reset versions is powered only during the opening stroke.

**Switch wiring diagrams** (see page 4) are part of each valve assembly, summarizing electrical data and wiring for a valve equipped with terminal block and a full complement of optional signal switches.

Diagrams show valve in its normally-closed (at rest) position. The indicated internal wiring is present only when the appropriate auxiliary switches are specified. Automatic reset valves always include a VOS-1 SPDT valve-open motor limit switch.

Good practice dictates that auxiliary switches in safety shutoff valves should be used for signal duty **only**, not to operate additional safety devices.

### Signal switch designations:

**VCS** (Valve Closed Switch) is actuated at the end of the "closing" stroke. VCS-1 is SPDT; VCS-2 is DPDT.

**VOS** (Valve Open Switch) is actuated at the end of the "opening" stroke. VOS-1 is SPDT; VOS-2 is DPDT.

Switch amp ratings are shown on the schematic wiring diagrams. **DO NOT EXCEED** rated amperage or total load shown.

Volt-Ampere (VA) Ratings

1516/1516U Manual Reset Valves				
	AC Operation		DC Operation	
Size	Opening	Holding	Opening	Holding
-1 (1") -2 (1 1/4")	22	22	14	14
1517/1517U Automatic Reset Valves				
-01 (1/2") -0 (3/4")	143	5	–	–
-1 (1") -2 (1 1/4")	220 <sup>⑤</sup>	22	212	14

⑤ 220 VA is for 60 hertz; if 50 hertz power, VA rating is 342.

**NOTE:** Total VA of solenoid and switches (manual reset valves) or solenoid, motor and switches (motorized valves) must not exceed the limits shown. The VA rating in the DC column is based on an AC motor and DC solenoid.

### Insurance authorities agree...

...the safety of any industrial fuel burning installation is dependent upon well-trained operators who are able to follow instructions, and to react properly in cases of emergency. Their knowledge of, and training on, the specific installation are both vital to safe operation.

Safety controls may get out-of-order without the operator becoming aware of it unless shutdowns result. Production-minded operators have been known to by-pass faulty controls without reporting the trouble.

Continued safe operation of any installation is then assured only if the plant management carefully develops an exact schedule for regular periodic inspection of all safety controls, insisting it then be rigidly adhered to.

A main gas manual shutoff cock should be located upstream from all other fuel train piping components and used to shut off all flow of fuel for servicing and other shutdowns.

All safety devices should be tested at least monthly† and more often if deemed advisable. Periodic testing for tightness of manual or motorized shutoff valve closure is equally essential.

† per NFPA 86

# ELECTRICAL DATA for normally-closed valves

## Manual Reset Valves 1"-1<sup>1</sup>/<sub>4</sub>" 1516/1516U

## Automatic Reset Valves 1"-1<sup>1</sup>/<sub>4</sub>" 1517/1517U

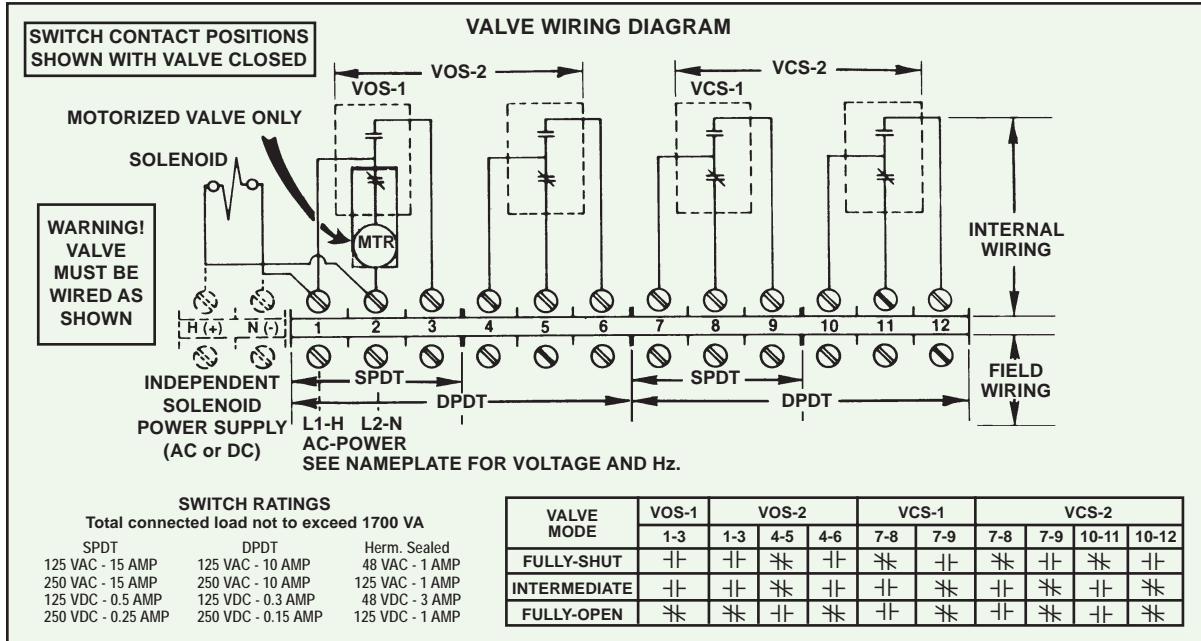

## Automatic Reset Valves 1/2" and 3/4" 1517/1517U

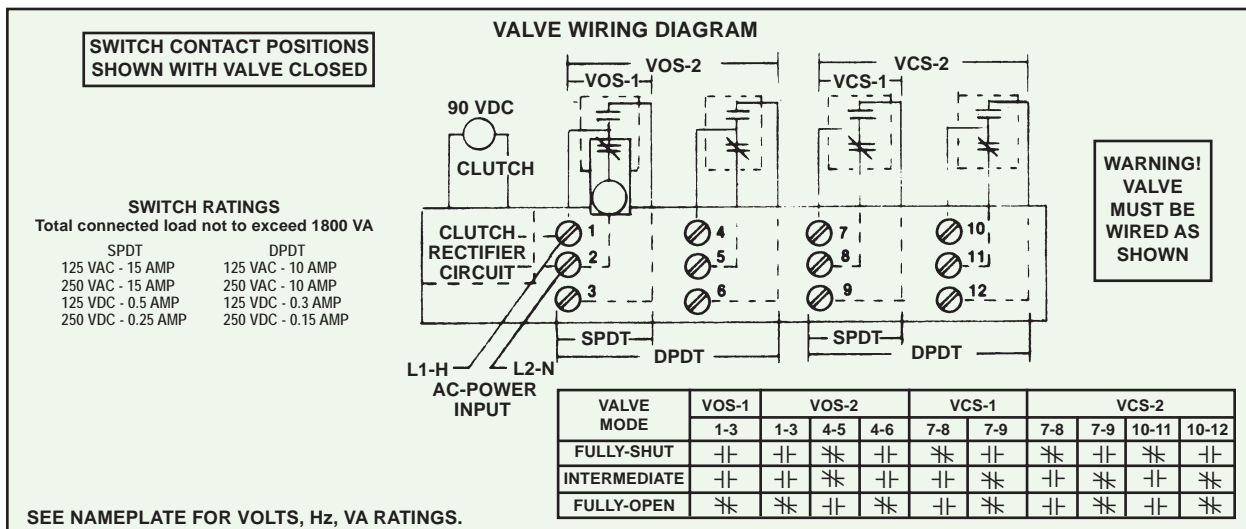

## VALVE BODY AND TRIM

**Trim identification** of oil shutoff valves is two-part. The first digit before the hyphen is a number (1, 2, 3 or 4) identifying body material as in Table 1 below. The second digit after the hyphen identifies trim utilizing the materials listed in Table 2.

Standard sanctioned valves incorporating a *cast iron body* will normally be identified by 1-B or 1-D. Sanctioned valves with *steel body* will normally be 2-D.

**Table 1. Body (Item 1) Specifications**

Body Description	Body 1-	Body 2-
<b>Material</b>	Cast Iron, G3000, CL30	Cast Steel
<b>ASTM Spec</b>	A159	A216-WCB

Non-sanctioned fuel services or unusual applications may require upgrading of internal trim. Contact North American with specific fuel analysis for price and availability.

The drawings shown carry item numbers matching those in the table. This information is furnished for identification only, not for ordering parts.

**WARNING: Do not attempt field repair of valve body or electro-mechanical top actuator. Any field alterations void all warranties.**

For Valve Assemblies, see Sheet 1516-1517-3.

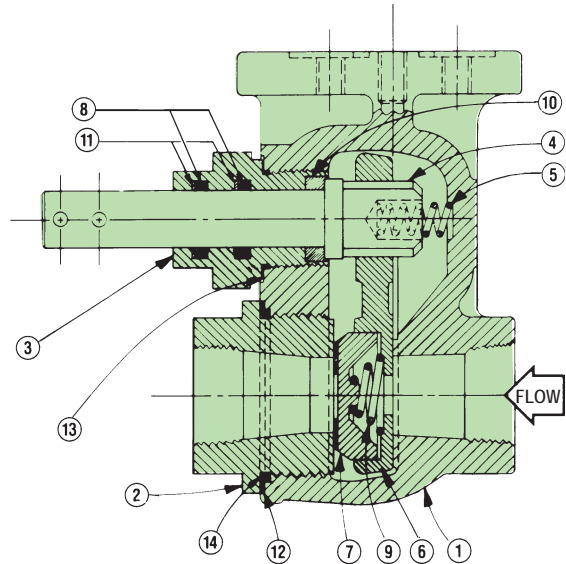
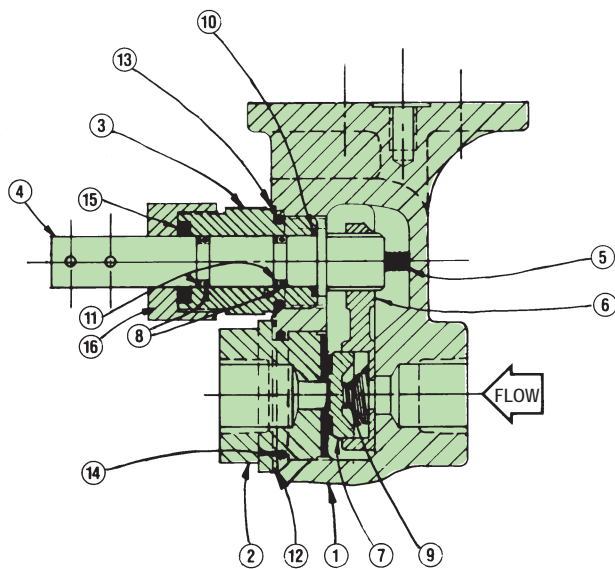

**Table 2. Internal Trim Material Specifications**

Item No.	Part Description	For 1/2" and 3/4" valves Trim -D	For 1" and 1 1/4" valves	
			Trim -B	Trim -D
2	Hex Nut or Renewable Seat	Hard-Faced Steel	Cast Iron with #420 Stainless Steel Seat Ring	Hard-Faced Steel
3	Stem Bushing	Zinc-Plated Steel	Zinc-Plated Steel	Zinc-Plated Steel
4	Stem	#416 Stainless Steel	#416 Stainless Steel	#416 Stainless Steel
5	Stem Spring	#302 Stainless Steel	#302 Stainless Steel	#302 Stainless Steel
6	Disc Carrier	Steel	Steel	Steel
7	Disc	Hard-Faced Steel	Nodular Iron	Hard-Faced Steel
8	Stem O-Rings	Hydrin	Viton	Viton
9	Disc Spring	#302 Stainless Steel	#302 Stainless Steel	#302 Stainless Steel
10	Inner Stem Thrust Ring	Teflon	Teflon	Teflon
11	Back-Up O-Rings	Teflon	Teflon	Teflon
12	Body Gaskets	Soft Iron	Soft Iron	Soft Iron
13	Stem Bushing Gasket	Soft Iron	Soft Iron	Soft Iron
14	Body O-Ring	Viton	Viton	Viton
15	Stem Packing Ring	Grafoil	-	-
16	Packing Nut	Zinc-Plated Steel	-	-

## COMPONENT IDENTIFICATION General Maintenance and Spare Parts

Every valve is tested and meets the requirements of ANSI B16.104 Class VI Seat Leakage.

1516/1517 Valves are designed for long trouble-free service. Only items shown as suggested spare parts are considered field replaceable.

**WARNING: Do not attempt field repair of valve body, top assembly, or motor drive unit. Any alterations void all warranties.**

**To determine suggested spare parts**, identify series designation and serial number from the valve's nameplate. Refer to the illustration and legend below to identify suggested spare parts.

**To order, specify:**

1. **Quantity**
2. **Assembly part number** (if available)
3. **Description**
4. **Electrical specification**
5. **Full nameplate information** (from existing valve)

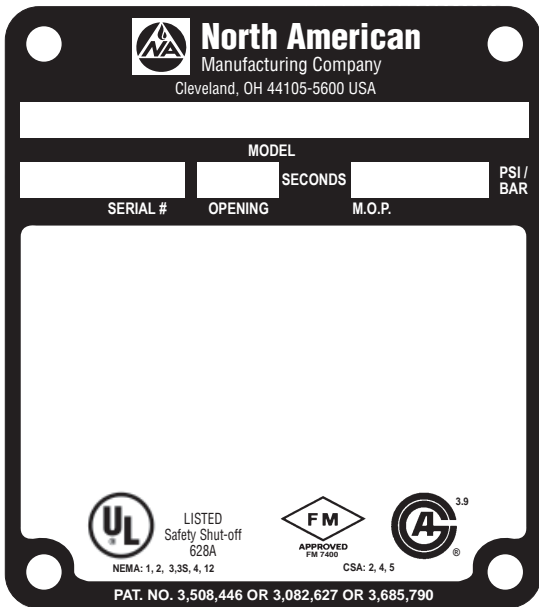

Nameplate (shown for listed valves; others similar)

Nameplate designation does not identify external accessory items or motor limit switch

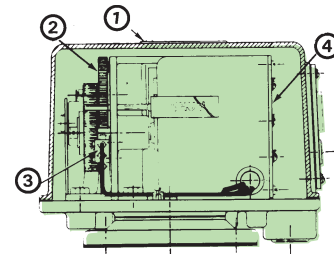

Series 1517/1517U  
-01, -0 only

**Legend:**

- ① Nameplate
- ② Motor Operator
- ③ VCS signal switch for normally-closed valve; VOS for normally-open valve
- ④ Printed Circuit Board (PCB)

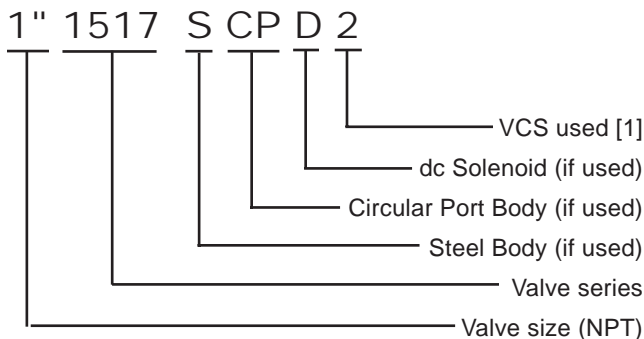

**[1] Signal Switch legend:**

- 0 No Switch
- 1 VOS-1 Switch
- 1H VOS-1 (Herm. Sealed)
- 2 VOS-2 Switch
- 2H VOS-2 (Herm. Sealed)

**NOTE:** VCS (Valve Closed Switch) and VOS (Valve Open Switch) are relative terms indicating valve gate position. In all valves, the top switch is contacted when valve body is in its normal "at rest" position. The opposite is true for the bottom switch.

**WARNING:** Situations dangerous to personnel and property may exist with the operation and maintenance of a combustion equipment. The presence of fuels, oxidants, hot and cold combustion products, hot surfaces, electrical power in control and ignition circuits, etc., are inherent with any combustion application. Parts of this product may exceed 160F in operation and present a contact hazard. Fives North American urges compliance with National Safety Standards and insurance Underwriters recommendations, and care in operation.

Fives North American Combustion, Inc., 4455 East 71st Street, Cleveland, OH 44105 USA, Phone 216.271.6000  
Fax 216.641.7852 email: fna.sales@fivesgroup.com • www.fivesgroup.com/fivesna