

1600-M Air motors are available for control systems that require limit switches on the air motor. These switches can be set to prove air valve position for high flow, purge and low fire start. The Dual Display Monitor has two SPDT limit switches mounted in a NEMA 4, 4X, 7 and 9 enclosure. Each switch can be actuated by a pair of touchset adjustable cams driven off the end of the air motor shaft. One cam determines the "ON" position of the switch, the other cam determines the "OFF" position. Each Dual Display Monitor is equipped with an indicator, which shows open or closed position for the valve. The Dual Display Monitor is UL Listed and CSA approved.

### Display Monitor SPECIFICATIONS

#### TECHNICAL DATA

- Conduit entries: NEMA 4: 1/2", NEMA 4, 7, 9: (2) 3/4"
- Die-cast aluminum enclosures--standard
- Coating: polyurethane
- Terminal strip capacity: 6 contacts--standard (additional contacts are available)
- Switch elements are hermetically sealed and UL listed

#### Electrical Ratings:

	SPDT
<b>Contact Resistance:</b>	0.150 ohms
<b>Contact Rating (ac, dc)*:</b>	3 watts
<b>Volts, max. (ac, dc):</b>	200
<b>Amps, max.</b>	0.25
<b>Amps, carry:</b>	1.2

\* Resistive: Reduce rating to 1/3 for inductive loads.

# 1600 AIR MOTOR with DUAL DISPLAY MONITOR

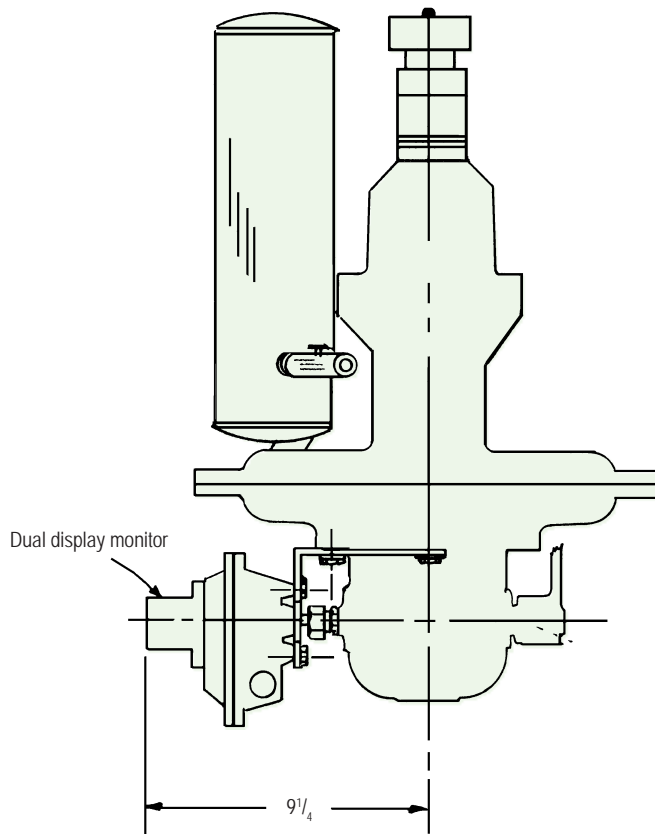

## Assembly Procedure

- 1) Install a  $\frac{5}{16}$ -18 jam nut onto the adapter stud up to the shoulder.
- 2) Remove (2)  $\frac{5}{16}$  bolts from the frame, one at 12 o'clock relative to the tapped end of the shaft and one at 3 o'clock.
- 3) Install the adapter stud into the shaft finger tight.
- 4) Install the mounting bracket with (1)  $\frac{5}{16}$ -18  $\times$  1" lg filister head bolt,  $\frac{5}{16}$  lock washer and flat washer at the 12 o'clock position and (1)  $\frac{5}{16}$ -18  $\times$  1" lg hex head bolt,  $\frac{5}{16}$  lock washer and flat washer at the 3 o'clock position. Do not tighten.
- 5) Place dual display monitor in position and align the shaft to the slot in the adapter.
- 6) Position the mounting plate and dual display monitor for proper alignment and install (4)  $\frac{5}{16}$ -18  $\times$   $\frac{1}{2}$ " lg hex head bolts and flat washers finger tight.
- 7) Tighten the bolts in the mounting bracket.
- 8) Tighten the bolts in the dual display monitor.
- 9) Tighten the jam nut.

# 1600 AIR MOTOR with DUAL DISPLAY MONITOR

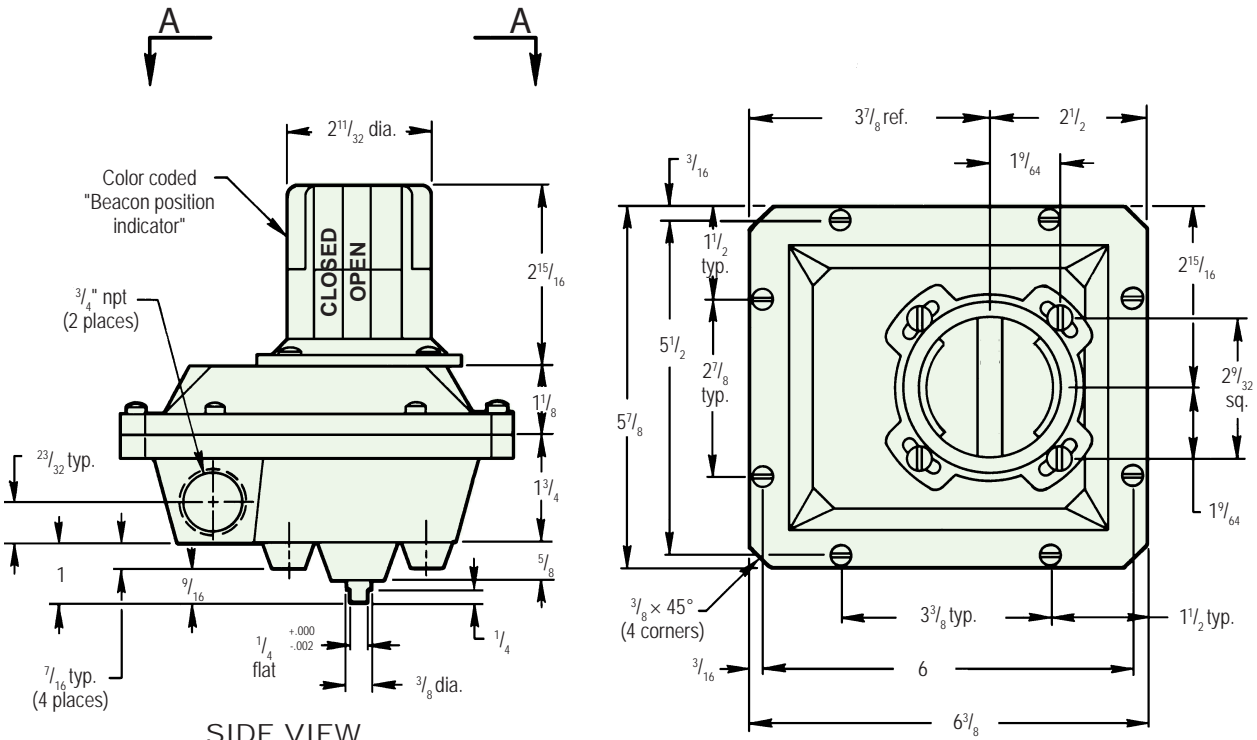

SIDE VIEW

TOP VIEW (A-A)

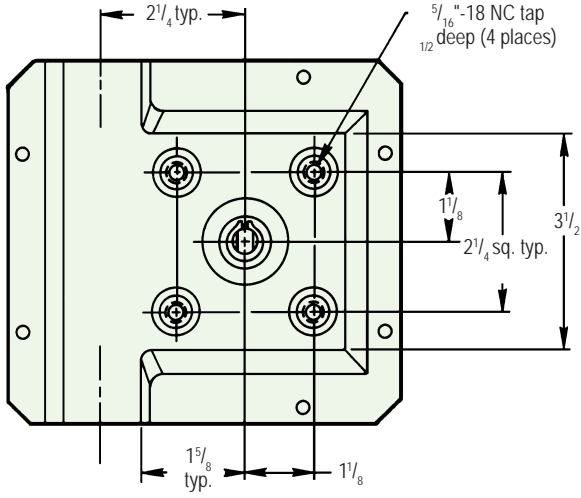

BOTTOM VIEW

## DIMENSIONS



## ORDERING INFORMATION

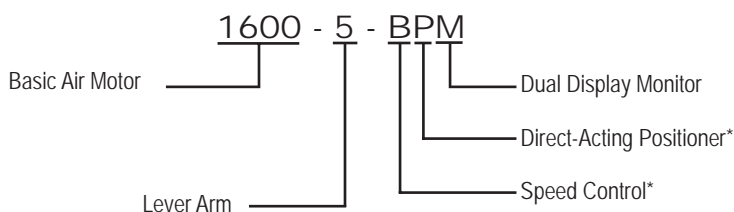

\* See Bulletins 1600, 1600-P, and 1600-BP for these options.



DIMENSIONS SHOWN ARE SUBJECT TO CHANGE. PLEASE OBTAIN CERTIFIED PRINTS FROM FIVES NORTH AMERICAN COMBUSTION, INC.  
IF SPACE LIMITATIONS OR OTHER CONSIDERATIONS MAKE EXACT DIMENSION(S) CRITICAL.

**WARNING:** Situations dangerous to personnel and property may exist with the operation and maintenance of an combustion equipment. The presence of fuels, oxidants, hot and cold combustion products, hot surfaces, electrical power in control and ignition circuits, etc., are inherent with any combustion application. Parts of this product may exceed 160F in operation and present a contact hazard. Fives North American urges compliance with National Safety Standards and insurance Underwriters recommendations, and care in operation.

Fives North American Combustion, Inc., 4455 East 71st Street, Cleveland, OH 44105 USA, Phone 216.271.6000

Fax 216.641.7852 email: [fna.sales@fivesgroup.com](mailto:fna.sales@fivesgroup.com) • [www.fivesgroup.com/fivesna](http://www.fivesgroup.com/fivesna)