

1813 Sensitrol Valve on a Dual-Fuel™ burner. Valve is used for setting ratio when burner is on oil; it is shut off when burning gas.

1813 Sensitrol Oil Valves are precision built, factory-calibrated valves for manual or motorized control of oil flow to industrial burners.

1813 Sensitrols are manual valves used as limiting orifices in setting oil/air ratio and as tight shutoff valves to prevent oil dribbling into burners during shutdown. An additional shutoff valve in the line which permits shutting off the burner without disturbing the Sensitrol's ratio setting position is recommended.

These valves have an adjustable detent mechanism that provides memory for desired valve operating position. A spring-loaded steel ball fits into a hollow in an adjustable collar, whose position is secured by a setscrew.

The handle can be pushed past the detent position easily to open the valve wide temporarily for light-off or clean-out.

1813- -K Manual Sensitrols have cutdown handles to lessen chances of accidental changes in valve setting.

1813M Motorized Sensitrols, for automatic control of oil flow, are available with brackets and linkage for most standard control motors. Although these valves have ten dial positions, linkage geometry limits valve travel to seven positions (e.g., 0-7, 2-9, or 3-10).

CONSTRUCTION

1813-03 and -02 Valves have forged brass bodies, Viton U-cup, and precision ground, hardened stainless steel port seats. A V-port in the upper, rotating disc exposes varying areas of a circular port in the lower seat. The triangular opening is highly resistant to clogging or fouling.

1813-01 and 1813M-01 Valves have cast brass bodies and precision ground, lapped conical seats that form a clog-resistant triangular opening.

1813- -K and 1813M Valves are UL Listed.

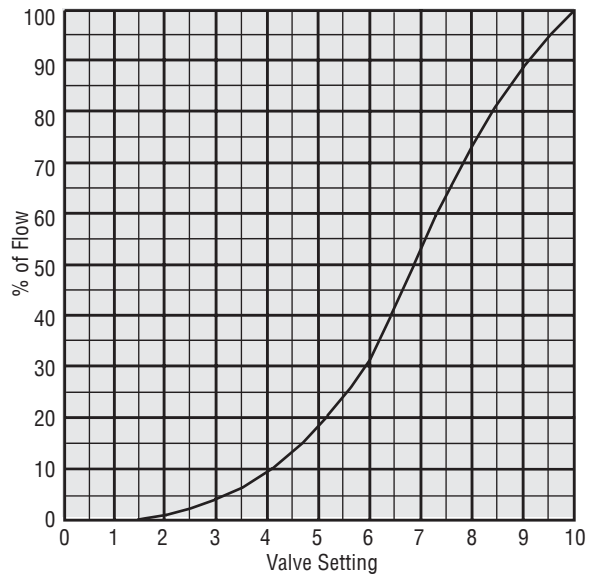

Figure 1. Typical oil flow vs. valve handle position at constant pressure drop. This generalized curve will not predict exact flow rates at handle positions other than #7, so do not use chart to set burner ratios.

CAPACITY

1813 Valves are factory calibrated for rated flow at No. 7 indicator position and can be used for metering at that setting only.

Sensitrol Valve Capacities at #7 Indicator Position 10 psi Pressure Drop

	Valve Size Designation					
	-03	-02-A	-02-B	-02-C	-02-D	-01
gph #2 Oil (40 SSU) at 10 psi ΔP	3	8	17	33	55	140
C_v Rating	0.015	0.039	0.083	0.16	0.26	0.66
Dial Color	Black	Red	Blue	Green	Brown	White
UL Dial Color	Yellow	Yellow	Yellow	Yellow	Yellow	Yellow

Flow at #10 (wide open) position is about twice the #7 position capacity. Shutoff occurs between positions #1 and #2 (see Figure 1).

To size Sensitrol for best control, determine oil flow rate required and available pressure drop. Using square root flow law, correct flow to 10 psi pressure drop. From Table above, select the valve with a capacity, at #7 position, closest to the corrected flow.

Example:

Select valve for 25 gph at 30 psi pressure drop (high fire).

$$25 \text{ gph at } 30 \text{ psi} = 25 \times \sqrt{\frac{10}{30}} = 14.4 \text{ gph at } 10 \text{ psi.}$$

1813-02-B (17 gph at 10 psi) is closest size.

Capacities are listed for 40 SSU #2 oil. They are somewhat less for higher viscosity oils but well within suitable ranges for oil burners (varying less than 10% from figures shown).

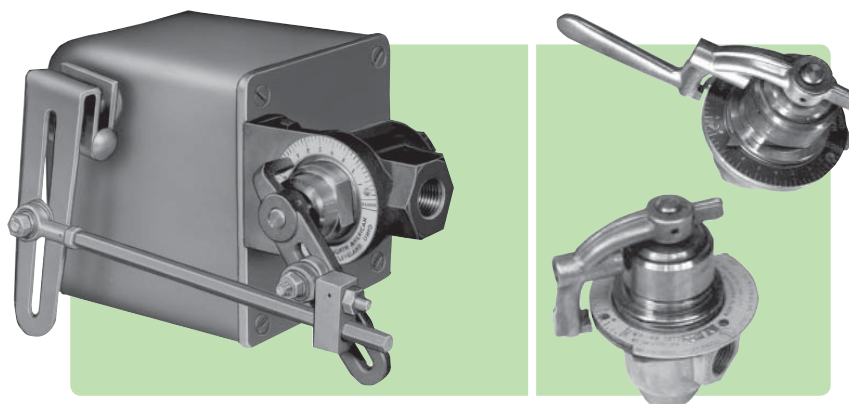
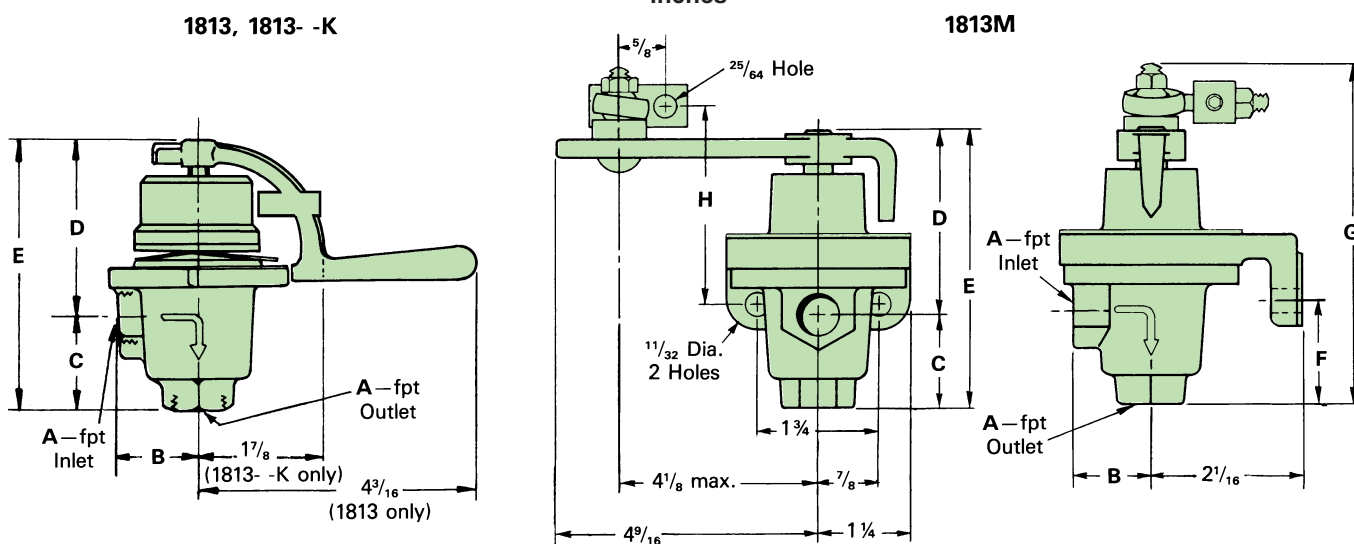

Figure 2. 1813M Motorized Sensitrol™ (left) with optional motor; 1813 Sensitrol (top right); 1813- -K Sensitrol (bottom right) with cutdown handle.

Maximum inlet pressure is 250 psi for 1813-03, -02; 100 psi for 1813-01. Maximum temperature is 300 F for all sizes.

DIMENSIONS inches



DIMENSIONS SHOWN ARE SUBJECT TO CHANGE. PLEASE OBTAIN CERTIFIED PRINTS FROM FIVES NORTH AMERICAN COMBUSTION, INC. IF SPACE LIMITATIONS OR OTHER CONSIDERATIONS MAKE EXACT DIMENSION(S) CRITICAL.

Valve Designation	dimensions in inches								Weight lb
	A	B	C	D	E	F	G	H	
1813-03, 1813-03-K	1/4	1/8	5/16	2 ⁹ / ₁₆	3 ⁷ / ₈	—	—	2 ⁹ / ₁₆	1 ¹ / ₂
1813M-03	1/4	1/8	5/16	2 ⁹ / ₁₆	3 ⁷ / ₈	1 ⁹ / ₁₆	4 ³ / ₄	2 ⁹ / ₁₆	2 ³ / ₄
1813-02, 1813-02-K	3/8	1/8	5/16	2 ⁹ / ₁₆	3 ⁷ / ₈	1 ⁹ / ₁₆	4 ³ / ₄	2 ⁹ / ₁₆	1 ¹ / ₂
1813M-02									2 ³ / ₄
1813-01	1/2	1 ⁵ / ₈	1 ⁵ / ₈	3 ¹ / ₁₆	4 ¹¹ / ₁₆	—	—	2 ⁷ / ₈	3 ¹ / ₄
1813M-01	1/2	1 ⁵ / ₈	1 ⁵ / ₈	3 ¹ / ₁₆	4 ¹¹ / ₁₆	2 ¹ / ₁₆	5 ³ / ₈	2 ⁷ / ₈	3 ³ / ₄

To order, specify: 1813-(code for pipe size)-(capacity letter where applicable) (K for cutdown handle, if applicable).

Examples: 1813-02-B Sensitrol Oil Valve
1813-02-BK Sensitrol Oil Valve

To order 1813M (Motorized) Sensitrol Valves use a similar scheme and either specify B and L, or add an X to 3rd term to indicate without B and L.

Examples: 1813M-02-B Valve with B & L for 1612-E
1813M-02-BX Valve w/o B & L

WARNING: Situations dangerous to personnel and property may exist with the operation and maintenance of an combustion equipment. The presence of fuels, oxidants, hot and cold combustion products, hot surfaces, electrical power in control and ignition circuits, etc., are inherent with any combustion application. Parts of this product may exceed 160F in operation and present a contact hazard. Fives North American urges compliance with National Safety Standards and insurance Underwriters recommendations, and care in operation.

Fives North American Combustion, Inc., 4455 East 71st Street, Cleveland, OH 44105 USA, Phone 216.271.6000
Fax 216.641.7852 email: fna.sales@fivesgroup.com • www.fivesgroup.com/fivesna