

## H3183 Discriminating Center Guide Detector



- Developed specifically for open weave fabrics
- Accommodates width changes without repositioning detectors
- Attenuates effect of ambient light
- Tolerant to passline changes
- Simple installation
- Rugged anodized aluminum housing

Fives North American's H3183 center guide detector is for use in applications that require center-guiding material with large product width variations. Used with a high frequency pulsed light source, such as the model H3137, the detector senses the intensity of the light projected on the area of the rectangular-shaped receivers. This light intensity varies with the lateral position of the process material, and thus represents material position relative to process centerline.

The processing circuitry discriminates between the high frequency pulsed light from the light source, and that of steady state ambient light. Thus, the circuit attenuates and does not react to most ambient light conditions.

Control is maintained during width changes, even at spliced joints. No repositioning of the detector is required during product width change.

The detector and light source are both easy to install and require no critical alignment. The distance between the detector and light source can range from two to ten feet (.6 to 3.0m) giving the user great flexibility in design.

## DIMENSIONS inches (mm)

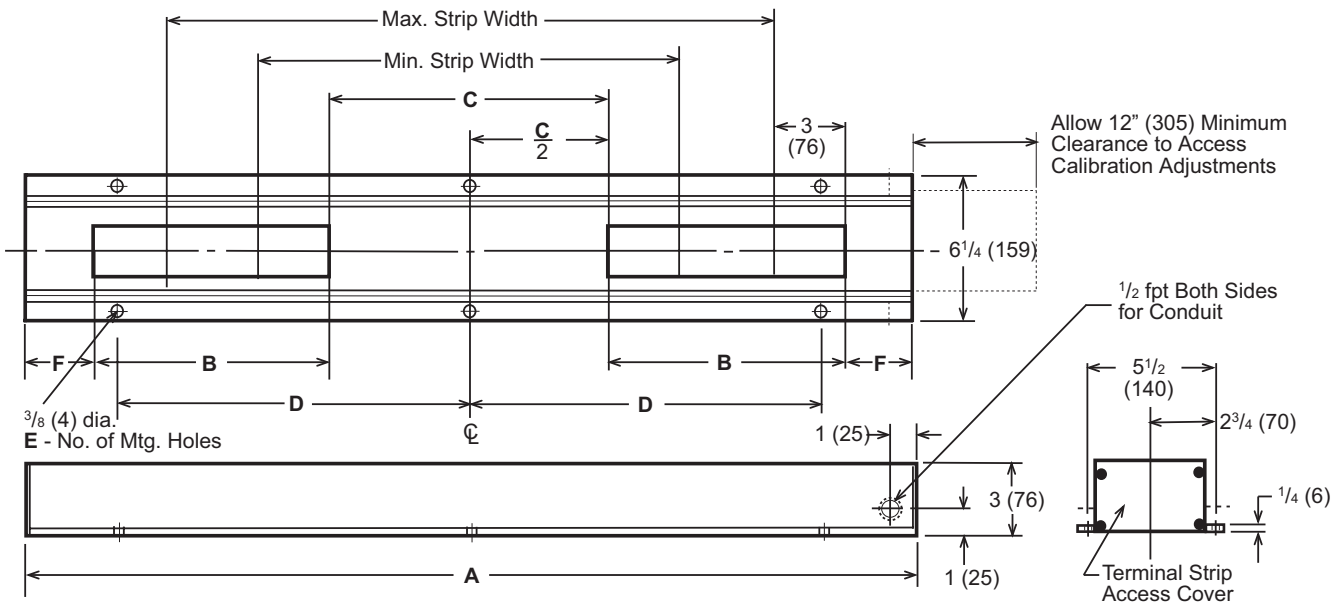

DIMENSIONS SHOWN ARE SUBJECT TO CHANGE. PLEASE OBTAIN CERTIFIED PRINTS FROM FIVES NORTH AMERICAN COMBUSTION, INC.  
IF SPACE LIMITATIONS OR OTHER CONSIDERATIONS MAKE EXACT DIMENSION(S) CRITICAL.

Model No. (see notes 1, 2, 4)	No offset ability		With ±3" (76) offset capability (see note 3)		Dimensions, inches (mm)						Light source
	max. inches (mm)	min. inches (mm)	max. inches (mm)	min. inches (mm)	A	B	C	D	F	E	
H3183-15-38	26 (660)	8 (203)	20 (508)	14 (356)	38 (965)	15 (381)	2 (51)	15 (381)	3 (76)	4	H3137-048-42
H3183-20-50	38 (965)	10 (254)	32 (813)	16 (406)	50 (1270)	20 (508)	4 (102)	20 (508)	3 (76)	6	H3137-060-56
H3183-27-62	50 (1270)	8 (203)	44 (1118)	14 (356)	62 (1575)	27 (686)	2 (51)	27 (686)	3 (76)	6	H3137-072-68
H3183-30-74	62 (1575)	14 (356)	56 (1422)	20 (508)	74 (1880)	30 (762)	8 (203)	27 (686)	3 (76)	6	H3137-084-80
H3183-20-86	74 (1880)	46 (1168)	68 (1727)	52 (1321)	86 (2184)	20 (508)	40 (1016)	39 (991)	3 (76)	6	H3137-096-92
H3183-33-86	74 (1880)	20 (508)	68 (1727)	26 (660)	86 (2184)	33 (838)	14 (356)	39 (991)	3 (76)	6	H3137-096-92
H3183-30-98	86 (2184)	38 (965)	80 (2032)	44 (1118)	98 (2489)	30 (762)	32 (813)	39 (991)	3 (76)	6	(2)H3137-048-42

See notes on page 3.

---

## SPECIFICATIONS

---

**Power requirements:**  $\pm 10$  to  $\pm 15$  VDC at 26 mA  
(nominal)

**Output signal:**  $\pm 10$  VDC nominal ( $\pm 14$  VDC maximum)

**Output impedance:** 100 ohms or less

**Ambient light rejection:**  
Greater than 48 dB at 120 Hz  
Greater than 50 dB at 60 Hz

**Light frequency sensitivity band:** 3 kHz to 10 kHz

**Frequency response:** 2 Hz

**Recommended face to face gap with light source:** 2 to 10 feet (.6 to 3m) [consult factory for larger gaps]

**Connections:** Terminal strip accessible from end cover

**Operating temperature:** 32-120 F (0-49 C)

**Housing material:** Anodized aluminum

**Lens material:** Polycarbonate

---

### NOTES:

1. Units are factory tested at 3' (1 m) gap. Calibration after installation is required for optimum results.
2. Use this column for systems with electronic offset, such as model H6220, H6220B or H6229.
3. Models with special housing lengths or rectangle sensor spacing are available as special order. To specify, use the following coding method.

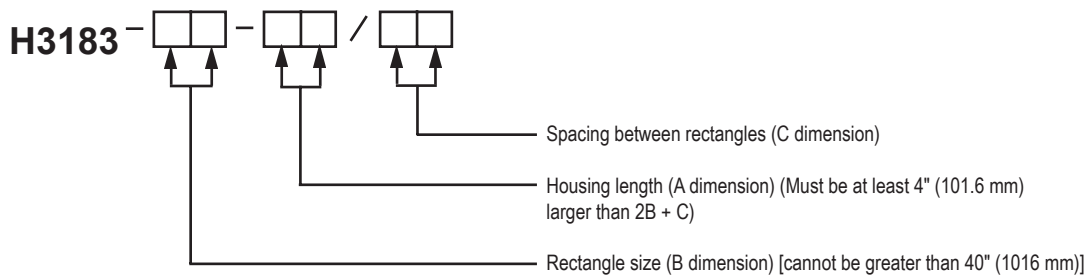

# **Fives North American...the Clear Choice for Your Web and Strip Guiding Needs.**

Offering an extensive array of products, capabilities, and experience, and a dedication to providing services to you for all phases of your guiding requirements, Fives North American is a company you can depend on for the right system for your specific needs.

- **Process Analysis**
- **Application Experience**
- **System Engineering**
- **Extensive Array of Products**
- **Quality Manufacturing**
- **Start-Up Assistance**
- **Parts and Service**
- **In Plant Training**

## **Guiding Experts Where and When You Need Them.**

Fives North American supports your guiding needs by providing experienced application specialists that are readily available to you. FivesNA's direct sales force are among the most knowledgeable in the industry. They have the ability to diagnose individual situations and offer the optimum guiding solution. Working together with an extensive corporate engineering staff, our field office locations across the U.S., Canada, and our international agents are ready to provide a quick response to your needs. Call us and we'll prove it to you!



**fives north american**

### **Fives North American Combustion, Inc. Guiding Systems**

4455 EAST 71st STREET, CLEVELAND, OH 44105 USA  
Tel: 216.271.6000 Fax: 216.641.7852

email: [fna.guiding@fivesgroup.com](mailto:fna.guiding@fivesgroup.com) • [www.fivesgroup.com/fivesna](http://www.fivesgroup.com/fivesna)